



English

Installation, Operation and Maintenance Instructions

Stormscreen

Spares & Service Contact Details

Mono UK

Spares	+44 (0)161 214 2380 (direct line 8.15 am – 5.00 pm)
E-mail	spares@mono-pumps.com
Service	+44 (0)161 214 2390 (direct line 8.15 am – 5.00 pm)
E-mail	customerservices@mono-pumps.com
Service	+44 (0)161 339 9000 (24 hrs)

Mono Australia

	Telephone	Facsimile
Melbourne	(03) 9580 5211	(03) 9580 9036
Sydney	(02) 9521 5611	(02) 9542 3649
Brisbane	(07) 3350 4582	(07) 3350 3750
Adelaide	(08) 8447 8333	(08) 8447 8373
Perth	(08) 9479 0444	(08) 9479 0400
Darwin	(08) 8984 3099	(08) 8947 0540
Tasmania	0417 345 814	(03) 6330 2051
E-mail	ozsales@mono-pumps.com	

Mono New Zealand

Spares & Service	+64 (0)9 829 0333
E-mail	info@mono-pumps.co.nz

Monoflo USA

Spares & Service	+1 713 466 7999
E-mail	inquire@monoflo.com

Monoflo South America

Spares & Service	+54 4296 8997	+54 4284 0323
E-mail	inquire@monoflo.com	

Mono China

	Telephone	Facsimile
Beijing	+86 (0) 10 6461 1115	+86 (0) 10 8486 8481
Shanghai	+86 (0) 21 5915 7168	+86 (0) 21 5915 6863
E-mail	monoshanghai@nov.com	

ATEX Warning Statements

SCREENS

Due to the nature and design of screening equipment it is possible that certain objects may enter the screening mechanism, from the process stream, with the potential to cause sparking or jamming of the mechanism.

Where a screen is to be installed in a potentially explosive atmosphere ensure that this has been specified at the time of purchase and that the equipment has been supplied accordingly and displays an ATEX nameplate or is supplied with a certificate of conformity. If there is any doubt as to the suitability of the equipment please contact Mono Pumps Limited before commencing with installation and commissioning.

Process liquids or fluids should be kept within specified temperature limits otherwise the surface of screen or system components may become an ignition source due to temperature rises. Where the process liquid temperature is less than 90°C the maximum surface temperature will not exceed 90°C provided the screen is installed, operated and maintained in accordance with this manual. Where the process fluid temperature exceeds 90°C the maximum surface temperature will be equal to the maximum process fluid temperature.

Cavities that could allow the accumulation of explosive gases, such as under guards, should where possible, be designed out of the system. Where this is not possible they should be fully purged before any work is carried out on the screen or system.

Electrical installation and maintenance work should only be carried out by suitably qualified and competent persons and must be in accordance with relevant electrical regulations.

All electrical equipment, including control and safety devices, should be suitably rated for the environment in to which they are installed.

Where there may be a risk of an accumulation of explosive gases or dust non-sparking tools should be used for installation and maintenance.

To minimise the risk of sparking or temperature rises due to mechanical or electrical overload the following control and safety devices should be fitted. A control system that will shut the screen down if the motor current or temperature exceed specified limits or a jam of the screening mechanism occurs. This may include a system that reverses the machine in order to clear any such jam. An isolator switch that will disconnect all electrical supply to the motor and ancillary electrical equipment and be capable of being locked in the off position. All control and safety devices should be fitted, operated and maintained in accordance with the manufacturer's instructions.

It is important that the screen rotates in the correct direction to give an efficient screening operation and ensure that debris is moved away from the screen as it should. This must be checked on installation and commissioning and after any maintenance has been carried out. Failure to observe this may lead to mechanical or electrical overload.

When fitting drives, couplings, and guards to a screen unit it is essential that these are correctly fitted, aligned and adjusted in accordance with the O&M instructions. Failure to do so may result in sparking due to unintended mechanical contact or temperature rises due to mechanical or electrical overload.

ATEX Warning Statements

Mechanical seals should be suitably rated for the environment. The seal and any associated equipment, such as a flushing system, must be installed, operated and maintained in accordance with the manufacturer's instructions.

Where a packed gland seal is fitted this must be correctly fitted and adjusted. This type of seal relies on the process liquid to cool the shaft and packing rings so a constant drip of liquid from the gland section is required. Where this is undesirable an alternative seal type should be fitted.

Failure to operate or maintain the screen and ancillary equipment in line with the manufacturer's instructions may lead to premature and potentially dangerous failure of components.

Regular inspection, and where necessary replacement, of bearings, seals, other wearing parts and lubrication is essential.

The screen and its components have been designed to ensure safe operation within the guidelines covered by legislation. Accordingly Mono Pumps Limited have declared the machine safe to use for the duty specified as defined by the Declaration of Incorporation or Conformity that is issued with this instruction manual. The use of replacement parts that are not manufactured by or approved by Mono Pumps Limited may affect the safe operation of the screen and it may therefore become a safety hazard to both operators and other equipment. In these circumstances the Declaration provided will become invalid. The guarantee referenced on the Terms and Conditions of Sale will also be invalidated.

Introduction

Stormscreen

This information and all the information contained herein, is the exclusive property of Mono Pumps Ltd, and contains information of a proprietary nature. It is provided for the sole purpose of transmitting the information contained to the designated recipient.

This information is to be used only as specified in the instrument of transmittal. It is not to be reproduced, copied in whole, or in part, nor is information it contains to be disclosed in any manner without the written consent of Mono Pumps Ltd. Its use for any other reason than the specified shall be a violation of the agreement with the recipient concerning the legal rights of Mono Pumps Ltd.

Mono Pumps Ltd reserves the right to make changes, which may obsolete certain parts of this manual.

The manual gives a guide to the operation and maintenance of the Stormscreen given that all Health and Safety and good engineering practices are observed.

Mono[®] NOV	
One Company, Unlimited Solutions	
	
MODEL No.	<input type="text"/>
SERIAL No./DATE	<input type="text"/>
WARNING	
WHERE APPLICABLE ENSURE THAT THIS MACHINE IS ELECTRICALLY ISOLATED AND CANNOT BE STARTED PRIOR TO REMOVING ANY FITMENT, GUARD OR INSPECTION COVER AND THAT ALL ITEMS SO REMOVED ARE REPLACED PRIOR TO RESTARTING.	
Martin Street Audenshaw Manchester M34 5DQ Tel: +44(0) 161 339 9000 Fax: +44 (0) 161 344 0727 www.mono-pumps.com MADE IN ENGLAND	

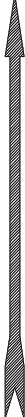
DIRECTION OF ROTATION

SECTION 1 OPERATING INSTRUCTIONS

SECTION 2 DIAGNOSTIC CHARTS

SECTION 3 WEIGHTS & LIFTING

SECTION 4 DRAWING REFERENCE NUMBERS

SECTION 5 DISMANTLING & ASSEMBLY DIAGRAMS

SECTION 6 MONO PRODUCTS

EC Declaration as defined by Machinery Directive 98/37/EC.

EC Declaration of Incorporation

This declaration is only valid when the machinery has been supplied without drive unit.

In this case, the machinery meets the requirements of the said directive ~~and is~~ intended for incorporation into other machinery or for assembly with other machinery in order to constitute relevant machinery as defined by the said directive including any amendments, which are valid at the time of supply.

IMPORTANT

This machinery must not be put into service until the relevant machinery into which it is to be incorporated has ~~been declared in~~ conformity to the said directive.

This declaration is only valid when the machinery has been installed, operated and maintained in accordance with these instructions and safety guidelines contained within as well as instructions supplied for equipment assembled with or intended for use with this equipment.

The following harmonised standards are applicable:

BS EN 809

BS EN ISO 12100 Parts 1 & 2

EC Declaration of Conformity

This declaration is only valid when the machinery has been supplied with drive unit.

In this case the machinery meets the requirements of the said directive including any amendments which are valid at the time of supply.

IMPORTANT

This declaration is only valid when the machinery has been installed, operated and maintained in accordance with these ~~instructions and~~ safety guidelines contained within as well as instructions supplied for equipment assembled with or intended for use with this equipment.

Mr  eer

Installation, Operation & Maintenance Instructions

1.0 ESSENTIAL HEALTH AND SAFETY

1.1 INSTALLATION AND SAFETY RECOMMENDATIONS

In common with other items of process plant a Stormscreen must be correctly installed to ensure satisfactory and safe operation. The Stormscreen must also be maintained to a suitable standard. Following these recommendations will ensure that the safety of personnel and the satisfactory operation of the Stormscreen is achieved.

1.1.1 GENERAL SAFETY

The noise sound pressure level will not exceed 70dB at one metre distance from the machine. This is based on a typical installation and does not necessarily include noise from other sources or any contribution from building reverberation.

Any warning sign supplied with the Stormscreen should be clearly displayed in close proximity to the machine.

The installation, repair and maintenance of the Stormscreen should only be carried out by suitably qualified persons with the relevant experience.



Before any work is carried out on the Stormscreen or motor controller (where applicable), be certain the main line breaker is open and tagged. Serious injury could result from accidental start up.

When checking for correct direction of rotation all personnel should be well clear of the Stormscreen.



The paddle wheel on the flow powered Stormscreen can still hold water after the machine has stopped. This gives the potential for sudden or unexpected operation at any time. These models are fitted with a locking device which should be activated prior to carrying out any work on the machines. (Refer to section 1 page 6 for details.) The Stormscreen should not be subjected to excessive external loads such as being stood on. Failure to observe this requirement may lead to damage and incorrect operation.

Due to the nature of the types of fluid screened by the Stormscreen it is recommended that the machine be steam cleaned prior to any work being carried out. This will reduce the risk of any biological or microbiological contamination. Where the necessary equipment is not available the Stormscreen should be thoroughly washed

down with clean water. The motor and drive unit (where applicable) should not be steam cleaned or washed down unless they are suitably rated.



When handling harmful or objectionable materials adequate ventilation must be provided in order to disperse dangerous concentrations of vapours.



Where persons, authorised or otherwise, could gain access to moving parts of the Stormscreen, suitable guards should be fitted where practicable. Where it's not practicable warning signs should be displayed.



All nuts, bolts, securing flanges and mounting fixtures should be checked for tightness prior to operation of the Stormscreen. All guards should be securely fixed and in compliance with current legislative requirements.

1.2.1 GENERAL

The flow enters the screen from the main channel and falls through the mesh on to the drive paddle. The solids are screened from the flow and retained on the mesh. As the drive paddle fills it turns and drives the brush mechanism via a toothed belt and timing gears. The brushes rotate, remove the retained solids from the mesh and return them to the main flow. The integral scum board protects the screen from the ingress of large floating debris.

For the motor powered Stormscreen the drive paddle assembly is replaced with either an overslung or direct coupled geared motor to turn the brush assembly.

It is recommended that wherever possible the Stormscreen should be installed with provision for adequate lighting, thus ensuring that effective maintenance can be carried out in satisfactory conditions.

1.3.1. HANDLING



During installation and maintenance, attention must be paid to the safe handling of all items. **Where a Stormscreen component weighs in excess 20kg* it is recommended that suitable lifting tackle be used to ensure that personal injury or damage to the components does not occur. *(Refer to section 4)**

Where slings are used for lifting components the sling positions should be selected according to the size and shape of the component.

Installation, Operation & Maintenance Instructions

Lifting should be carried out by personnel with relevant experience to ensure that personal injury or damage to the components does not occur.

If eyebolts do exist they should only be used for lifting the individual component for which they are supplied.

Lifting of the assembled Stormscreen should only be via the designated lifting points and using the recommended equipment. (See illustrations in section 3)

1.3.2. STORAGE

The Stormscreen units are dispatched from our factory ready for immediate installation and operation.

Where the Stormscreen has to be stored prior to installation the following procedure is advised:-

- (1) Store the Stormscreen inside wherever possible. If this is not feasible a protective covering should be provided. Do not allow moisture to collect around the Stormscreen.
- (2) At monthly intervals the shafts should be rotated to prevent flat spots on the bearings. This is most easily achieved by rotating the paddle wheel by hand the Stormscreen.



When operating the Stormscreen by hand extreme care should be taken to ensure hands and fingers do not become caught in the mechanism.

- (3) For information regarding storage of the motor and drive unit refer to the manufacturer's instructions.

1.4 ELECTRICAL (Where applicable)



Electrical connection should only be made by suitably qualified personnel using equipment suitable for both the rating and the environment. Where any doubts exist regarding the suitability of equipment, Mono Pumps should be consulted before proceeding. Earthing points will be provided on electric drives (if supplied) and it is essential that these be correctly connected. The electrical installation should include appropriate isolating equipment to ensure the Stormscreen is safe to work on.

DUTY CONDITIONS

The Stormscreen should only be installed on duties for which Mono Pumps Limited have specified the materials of construction, flow rates and head conditions etc.

If the duty conditions should be changed, Mono Pumps Limited should be contacted and their recommendations sought in the interest of application, plant safety and Stormscreen life.

By hand extreme care should be exercised to ensure hands and fingers do not become caught in the mechanism.

Installation, Operation & Maintenance Instructions

2.0 SYSTEM DESIGN AND INSTALLATION

Required Weir Wall Dimensions

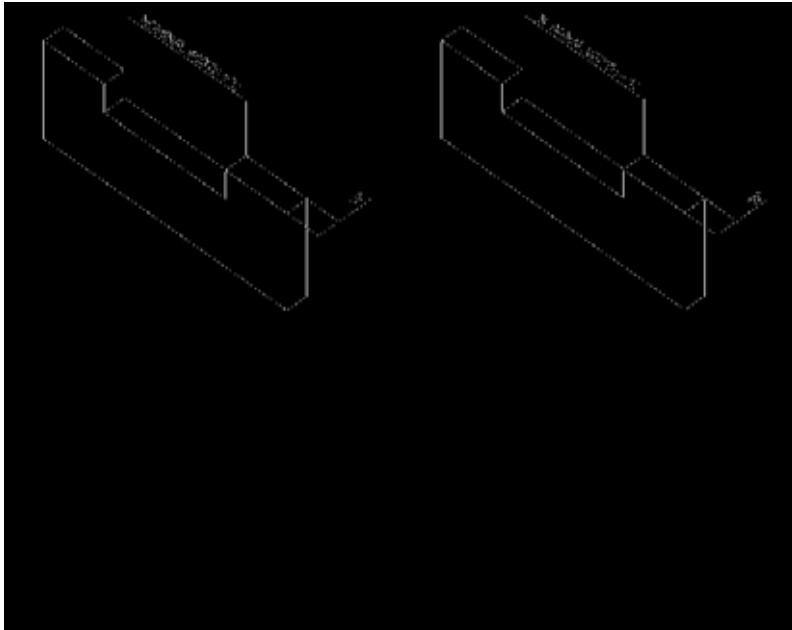

Figure 1
Weir wall requirements

Drive Option	Minimum Required 'L'	Minimum Recommended 'L'	Drum Diameter	Required 'W' (+/- 30mm)
Flow Powered	400	550	400 mm	200 mm
Overlunge Motor	400	550	700 mm	300 mm
Direct Coupled	635	755		

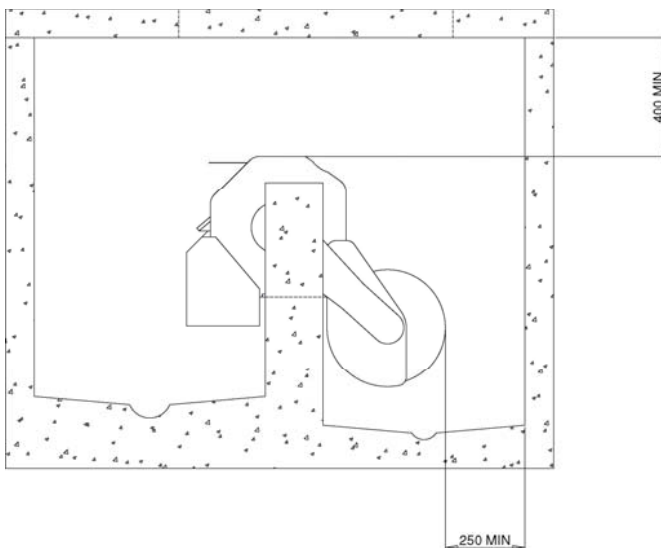

Figure 2
Minimum recommended space required around the Stormscreen for maintenance.

2.1 CIVILS DESIGN

At the design stage due consideration must be given to the design of the civil works. These must have sufficient mechanical integrity to support the imposed loads due to the weight of the Stormscreen and the hydraulic loads due to the flow conditions. Also, in the unlikely event of Stormscreen breakdown, the civil works should be able to contain the extra upstream head caused by the flow restriction of the offline Stormscreen. The Stormscreen should be bolted directly to the weir wall or mounted in a purpose built support frame.

For ease of installation and removal for maintenance we strongly recommend the use of a guide rail system. Consult Mono Pumps Limited for further details.

If the Stormscreen is to be mounted in any other way than described above, confirmation of the installation must be agreed with Mono Pumps Limited.

2.2 FIXING METHODS

The Stormscreen can be fitted directly to the weir wall when the wall is sound, substantial and of regular form. This can be done using masonry anchors mounted directly into the wall in drilled holes. Where the weir wall is too narrow, weak or of irregular form, it is possible for Mono Pumps Limited to design and supply tailor-made mounting fixtures. Alternatively a guide rail system can be supplied to suit specific requirements. This allows the Stormscreen to be easily raised to the surface and is recommended where access for maintenance and cleaning is difficult.



When entering the storm chamber all relevant health and safety regulations must be followed. To avoid the need to enter the storm chamber, where possible, the Stormscreen should be raised to the surface for maintenance.

2.3 INSTALLATION GUIDELINES

Ensure the design of the channel is such that it creates sufficient flow velocity to prevent deposition of solids and that there are no areas where solids can build up. The foul side should be benched to ensure that solids fall away from the Stormscreen and back in to the main flow as the storm condition subsides.

Installation, Operation & Maintenance Instructions

There should be at least 250mm below the bottom of the scumboard and the channel or chamber floor on the foul side.

On flow powered machines, at maximum spill conditions, the spill flow level should be below the bottom of the paddle wheel. Where this is not possible the efficiency of the Stormscreen may be affected.

Consideration must be given to potential flooding or over-topping of the channel or chamber in the event of a screen failure. Where this is critical it is recommended that an emergency overflow weir be included in the civils design. Where flooding of the chamber is likely, electrically powered Stormscreens should be fitted with a suitably rated motor.

To prevent distortion of the Stormscreen assembly the mounting surface of the weir wall should be flat and level and of the required thickness as shown in **Figure 1**. Where the weir wall is not suitable it may be possible to use shims to level the Stormscreen, otherwise it should be mounted on a support frame. Please contact Mono Pumps Limited for further details.

For ease of installation and removal an access cover should be fitted directly above the Stormscreen. Where possible this should be large enough to allow the machine to pass through un-restricted as a complete assembly.

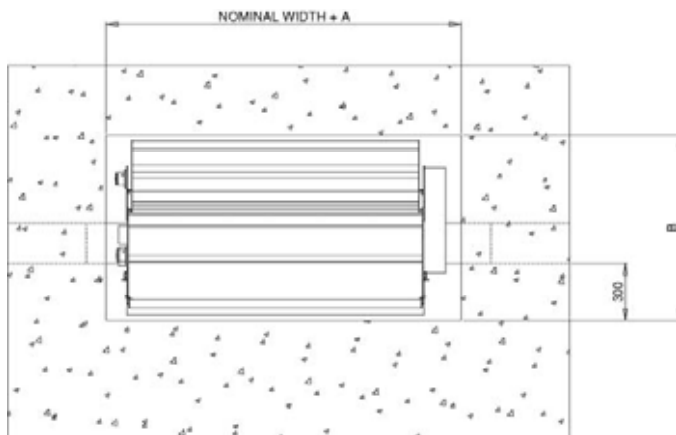

Figure 3

Minimum recommended access opening

Drive Type	400 drum		700 drum	
	A	B	A	B
Flow Powered	300	950	300	1300
Overslung Motor	300	700	300	850
Direct Coupled Motor	400	600	400	800

The minimum recommended access opening sizes are shown in **Figure 3**. These allow the Stormscreen to be installed and removed in one piece. Where it is not possible to achieve the minimum opening size the Stormscreen can be partly dismantled to allow installation and removal. Please consult Mono Pumps Limited for details.

2.4 COMMISSIONING CHECKS

Once the Stormscreen has been installed its Operation should be checked as follows:

(1) BRUSH ADJUSTMENTS

The top of the brushes should interfere with the mesh by approximately 1mm. Excessive interference may cause the screen to jam or operate intermittently. The brushes should be in contact with the mesh across its full width and through the full contact angle. (Refer to page 6 for Brush adjustment method).

(2) SCRAPER ADJUSTMENTS

The tip of the scraper should contact the brushes as low down as possible without fouling on the metal brush carrier. The scraper assembly should pivot freely and return to its rest position when released. Instructions for the adjustment of the scraper are given on page 6.

(3) PADDLE WHEEL END FLOAT (FLOW POWERED ONLY)

The Paddle wheel should have approximately 5 to 8mm of end float. Ensure that the mounting flanges do not foul on the side panels of the paddle assembly.

(4) REQUIRED TORQUE

Check that the maximum torque required to turn the Stormscreen does not exceed the values shown below.

	750	1000	1250	1500	1750	2000
400 Drum	10	13	17	20	24	27
700 Drum	25	34	43	52	60	69

The torque requirement may be checked by screwing an M10 bolt into the end of one of the shafts and using a torque wrench set to the specified value.

There should be no jumping of the drive belt (where applicable).

Installation, Operation & Maintenance Instructions

3.0 OPERATION OF SAFTEY LOCKING DEVICE

In addition to the commissioning checks above the following additional checks should be made periodically. The inspection period will vary accordingly to frequency of operation, the nature of the flow and other site conditions and a suitable schedule should be established on a site by site basis.



Prior to carrying out any inspection or maintenance the Stormscreen must be made safe. On flow powered screens the paddle wheel should be locked (see below). On motorised screens the electrical isolator should be locked open.

Locking Device Arrangement

Device Engaged

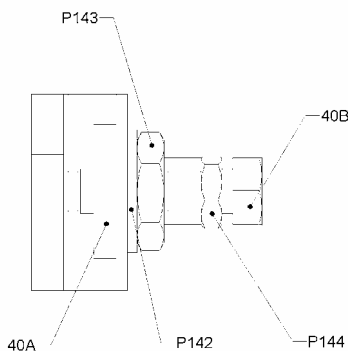

Device Dis-engaged

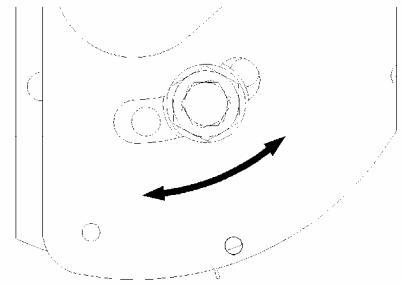
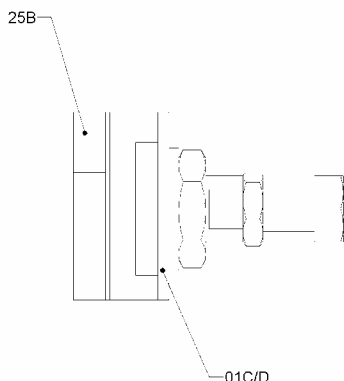

Under normal operation the device is dis-engaged and locked in this position using the small locknut, P144. The entire assembly is then located securely on the Paddle Wheel End Plate using the large locknut, P143.

To activate the device both locknuts should be loosened so the entire assembly is free to move within its slot in the Paddle Wheel End Plate, 01C/D and the screw, 40B, can be adjusted in and out. The screw can then be adjusted so it protrudes into the most convenient hole in the Paddle Wheel, 25B, and locked in position using the small locknut. To prevent any rotation of the Paddle Wheel, the Safety/Maintenance Locking Device should then be locked in position using the large locknut.

4.0 VISUAL INSPECTION

Check the Stormscreen for evidence of operation such as retained solids on the mesh or brushes. If required any solids should be removed either by pressure washing or by hand.

Check for evidence of over topping such as solids on the 'clean' side of the mesh or in the spill chamber. If this is evident and the Stormscreen appears to be operating correctly check for other causes such as down stream restriction on the front side or an extreme storm condition.

Check for signs of mechanical damage and repair or replace any damaged components as required. (Refer to the parts list in section 4 pages 1 and 2 or consult Mono Pumps Limited).

4.1 OPERATIONAL CHECKS

Ensure the brush carrier and paddle wheel (where applicable) are free to rotate. There should be no jumping of the drive belt (where applicable). A consistent force should be required through the full rotation of the machine except where the brushes contact with the scraper. At this point more effort will be required.

Installation, Operation & Maintenance Instructions

The scraper should ride up the bristles of the brush and then return freely to the rest position under the action of the return springs alone.

If the operation of the Stormscreen is in anyway impaired investigate and rectify the cause. (Refer to the diagnostic charts in section 2 page 1).

Once all the above checks have been carried out disengage the paddle locking device or re-connect the electrical supply and check the operation of the screen. On flow powered models this can be achieved by filling the paddle wheel with water or turning the paddle by hand.

5.0 ROUTINE MAINTENANCE

It will be easier to carry out the routine maintenance if the Stormscreen can be lifted from the installation and taken to a workshop facility. If this is not feasible it is possible to carry out the work with the screen in situ.



Where this is necessary due attention should be given to all relevant Health and Safety requirements.

The following maintenance actions should be carried out every 12 months.

Refer to dismantling and assembly diagrams

Caution: When servicing the Stormscreen or motor controller (where applicable), be certain the main line breaker is open and tagged. Serious injury could result from accidental start up. Disconnect and tag motor leads in motor terminal box.

5.1 BEARINGS AND SEALS

- (1) Remove screws P104 from pulley guard 15A.
- (2) Loosen screws P120 and disengage the pulley tensioner from the belt 78C.
- (3) Remove the timing belt 78C and anti-backlash gears 78A/B.
- (4) Remove screws P113. Remove bearing housing 02A.
- (5) Remove outer lipseal P114. Remove outer spiral-retaining ring P115.
- (6) Remove inner spiral-retaining ring P115. Remove inner lipseals P117. Remove spiral retaining P115.
- (7) Press out bearing P116.

- (8) Inspect bearing housing 02A and shaft 32A/B for signs of leakage or contaminants, if any are found bearings and/or lipseals are worn and must be replaced.

- (9) Re-assemble in reverse order.

5.2 BRUSHES

- (1) Rotate brush carrier 25A by hand and visually check all brushes 35A have continuous 1mm engagement with mesh 22A. If continuous engagement is not achieved or brushes have taken an excessive permanent set the brushes are worn and must be adjusted (see 4.1) or replaced.

5.3 LUBRICATION SCHEDULE

Routine replenishment of the bearing housing grease is not necessary. If, during bearing and seal inspection, excessive moisture is present the cause should be investigated and rectified and the lipseals re-packed with the specified lubricants.

RECOMMENDED LUBRICANTS

Shell Alvania No. 2EP (-9°C to 82°C) or BP Energrease LC2 (-30°C to 180°C)

NOTE: WHEN CHECKING FOR CORRECT BRUSH ROTATION ALWAYS ENSURE THAT PERSONNEL ARE WELL CLEAR OF PADDLE AND BRUSH WHEELS.

5.4 ADJUSTMENTS

- (1) Brush adjustment may periodically be required. Brushes should always be in contact with the mesh inner surface within the mesh arc and should contact by 1-2mm. Adjustment is carried out via the brush securing screws P113. Excessive brush clearance will result in deposit build-up on inner mesh surface. Excessive brush interference, increase operating torque levels and over stress drive components.
- (2) The scraper is designed to clear deposits from the brush on every revolution and correct adjustment is essential for operation. The brush should contact the scraper tangentially. Lateral adjustment of the scraper strip is via screws P135 and nuts P127.
- (3) Drive belt tension adjustment is via screws P120 in the tensioner slide 39A. Correct belt pre-load is reached when the belt can just be turned through 90° at the mid point on the drive side between the two pulleys.

Diagnostic Charts

Flow Powered

SYMPTOMS	POSSIBLE CAUSES
<ol style="list-style-type: none"> EXCESSIVE HEAD. PADDLE WHEEL ROTATES – BRUSHES STATIONARY. PADDLE WHEEL & BRUSHES STATIONARY. EXCESSIVE BLINDING. STORMSCREEN REQUIRES HIGH FLOW TO ROTATE. EXCESSIVE VIBRATION OF UNIT WHEN IN OPERATION. 	<ol style="list-style-type: none"> 1.2.3. 4. 1.4.5. 2.3.4. 1.2.3.5. 6.
LIST OF CAUSES	REMEDIAL ACTIONS
<ol style="list-style-type: none"> EXCESSIVE BLINDING ON MESH. WORN BRUSHES. BRUSHES SET INCORRECTLY. DRIVE BELT FAILURE. BRUSH / PADDLE WHEEL BLOCKAGE / JAM. UNIT FIXING POINT LOOSE. 	<ol style="list-style-type: none"> CLEAN MESH. REPLACE / ADJUST BRUSHES. ADJUST BRUSHES. REPLACE/REFIT DRIVE BELTS. RELEASE BLOCKAGE. TIGHTEN FIXINGS ON BASEPLATE/SHIM TO SUIT.

Direct Coupled

SYMPTOMS	POSSIBLE CAUSES
<ol style="list-style-type: none"> EXCESSIVE HEAD. BRUSHES DO NOT TURN. EXCESSIVE BLINDING. EXCESSIVE VIBRATION OF UNIT WHEN IN OPERATION. INCORRECT DIRECTION OF ROTATION 	<ol style="list-style-type: none"> 1.2.3. 4.5. 2.3. 6. 7.
LIST OF CAUSES	REMEDIAL ACTIONS
<ol style="list-style-type: none"> EXCESSIVE BLINDING ON MESH. WORN BRUSHES. BRUSHES SET INCORRECTLY. DRIVE FAILURE. BRUSH / BLOCKAGE / JAM. UNIT FIXING POINT LOOSE. MOTOR INCORRECTLY WIRED. 	<ol style="list-style-type: none"> CLEAN MESH. REPLACE / ADJUST BRUSHES. ADJUST BRUSHES. CHECK AND REPLACE MOTOR/GEARBOX. RELEASE BLOCKAGE. TIGHTEN FIXINGS ON BASEPLATE. RE-WIRE MOTOR FOR CORRECTION DIRECTION OF ROTATION.

Overslung

SYMPTOMS	POSSIBLE CAUSES
<ol style="list-style-type: none"> EXCESSIVE HEAD. BRUSHES DO NOT TURN. MOTOR OPERATES BUT BRUSHES DO NOT ROTATE. EXCESSIVE BLINDING. EXCESSIVE VIBRATION OF UNIT IN OPERATION. INCORRECT DIRECTION OF ROTATION. 	<ol style="list-style-type: none"> 1.2.3. 4.5.8. 4. 2.3.4. 6. 7.
LIST OF CAUSES	REMEDIAL ACTIONS
<ol style="list-style-type: none"> EXCESSIVE BLINDING ON MESH. WORN BRUSHES. BRUSHES SET INCORRECTLY. DRIVE BELT FAILURE. BRUSH / BLOCKAGE / JAM. UNIT FIXING POINT LOOSE. MOTOR INCORRECTLY WIRED. MOTOR/GEARBOX FAILURE. 	<ol style="list-style-type: none"> CLEAN MESH. REPLACE / ADJUST BRUSHES. ADJUST BRUSHES. REPLACE/REFIT DRIVE BELT. RELEASE BLOCKAGE. TIGHTEN FIXINGS ON BASEPLATE. RE-WIRE MOTOR FOR CORRECTION DIRECTION OF ROTATION. CHECK AND REPLACE MOTOR/GEARBOX.

Machine Weights and Lifting

MACHINE WEIGHTS

Approx Weight (kg)

DRUM DIA. (mm)	NOMINAL WIDTH (m)	FLOW POWERED	DIRECT COUPLED MOTOR	OVERSLUNG MOTOR
400	0.75	135	115	110
	1.00	160	140	130
	1.25	185	150	145
	1.50	215	170	165
	1.75	240	185	180
	2.00	265	205	195
700	0.75	220	175	170
	1.00	255	195	190
	1.25	290	215	210
	1.50	330	235	230
	1.75	365	255	250
	2.00	400	275	270

Note: Above weights are based on standard depth scumboard.

Lifting Gear C010 9955 – For machines up to 1.25m width

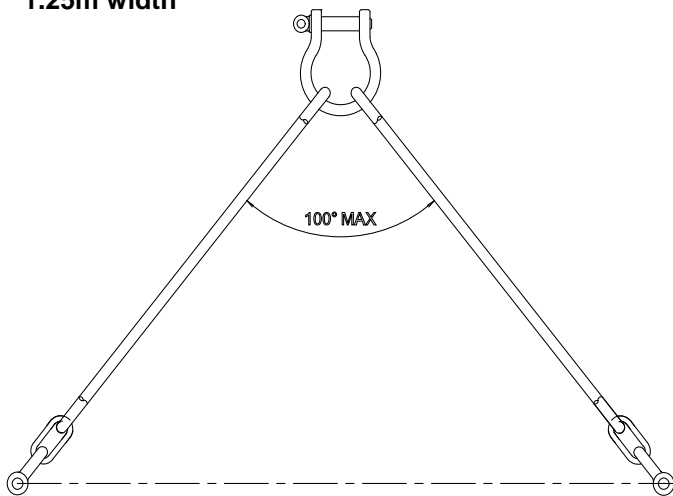

Lifting Gear C017 9955 – For machines 1.5m wide and upwards

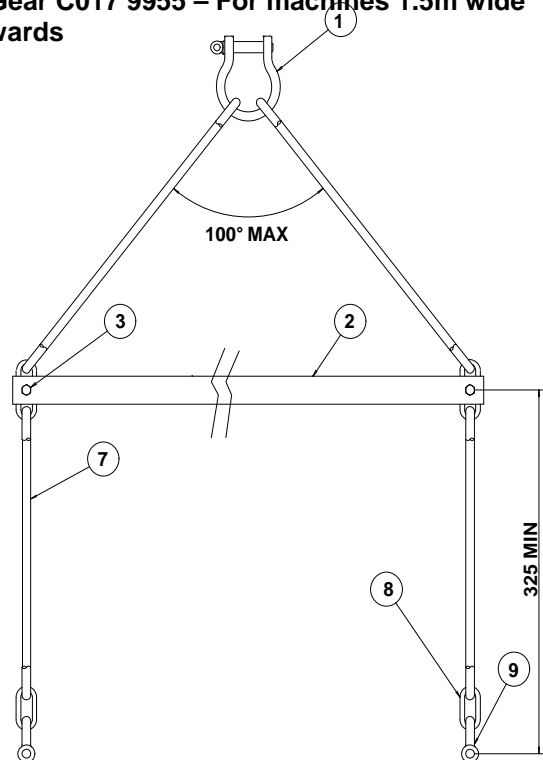

BOLT/SCREW TIGHTENING TORQUES

SIZE	Nm	lbf.ft
M6	10	7
M8	20	15
M10	40	30
M12	70	52

All threaded fasteners to be fitted using Loctite 243 or equivalent

Drawing Reference Numbers

ITEM	DESCRIPTION	CODE	PART No.
01A #	TOP SIDE PANEL - DRIVE SIDE	SO/SF	C*00 01**
01B #	TOP SIDE PANEL - NON-DRIVE SIDE	SO/SF	C*00 01**
01C	PADDLE SIDE PANEL - DRIVE SIDE	SO/SF	C*00 010*
01D	PADDLE SIDE PANEL - NON-DRIVE SIDE	SO/SF	C*00 011*
01E	MESH SUPPORT RIB	SO/SF	C*00 0120
02A	BEARING HOUSING	SO/SF	C400 0200
02B	SEAL HOUSING	SO/SF	C400 0210
06A	NAMEPLATE	SF	C000 0600
15A	PULLEY GUARD	SO/SF	C*00 15*0
16A	SPLASH GUARD	SO/SF	C*** 1600
17A	BAFFLE MOUNTING PLATE	SO/SF	C400 1700
22A	MESH	SO/SF	C*** 22**
23A	FLOW GUIDE – UPPER	SO/SF	C*** 2300
23B	FLOW GUIDE – LOWER	SO/SF	C*** 2310
25A #	BRUSH CARRIER ASSEMBLY	SO/SF	C*** 2500
25B #	PADDLE WHEEL ASSEMBLY	SO/SF	C*** 2510
32A	DRIVE SHAFT	SB	C400 32*0
32B	DRIVEN SHAFT	SB	C400 3220
35A	STRAIGHT BRUSH	OO	C4** 3500
35B	BRUSH BACKING STRIP	SO/SF	C4** 3510
37A	MESH SUPPORT RAIL	SO/SF	C4** 3700
37B	MESH STIFFENER BAR	SO/SF	C4** 3710
38A #	SCUM-BOARD	SO/SF	C*** 380*
39A	BELT TENSIONER BRACKET	SO/SF	C400 3900
39B	BELT TENSIONER ROLLER SET	OO	C000 3915
40A	LOCKING DEVICE BOSS	SB	C000 4000
40B	LOCKING DEVICE SCREW	SO/SF	C000 4001
62A #	BASEPLATE ASSEMBLY	SO/SF	C*** 6200
65A	PANEL BRACING BAR	SO/SF	C7** 6500
66A	UPPER BRACING BAR	SO/SF	C*** 6600
76A	OVERSLUNG MOTOR BRACKET	SO/SF	C*00 7600
78A	DRIVE GEAR	AH	C000 780*
78B	DRIVEN GEAR	AH	C000 780*
78C	DRIVE BELT	OO	C*00 78*0
81A	SCRAPER	PD	C*** 8100
81B	SCRAPER SUPPORT	SO/SF	C4** 8110
81C	SCRAPER BACKING STRIP	SO/SF	C*** 8120
81D	RETURN SPRING TAB	SO/SF	C400 8130
81E	SHOULDER BOLT	***	C400 8140
81F	RETURN SPRING	***	C*00 8150
81G	RETURN SPRING LOCATOR	SO	C400 8160
99A	LIFTING GEAR	MB	C01* 9955

* DENOTES VARIATION SPECIFIC TO MACHINE.

DENOTES COMPONENT IN EXCESS OF 20KG.

Drawing Reference Numbers

ITEM	DESCRIPTION	CODE	PART No.
P101	M12 x 25 SOC HD CAP SCREW	***	A115222F
P102	M12 SPRING WASHER	***	W115251F
P103	M12 HEX NUT	***	N115100F
P104	M12 x 20 SOC HD CAP SCREW	***	A115202F
P105	M12 x 40 SOC HD CAP SCREW	***	A115282F
P106	M8 x 20 BUTTON HD SCREW	***	H113202F
P107	M6 x 16 SOC HD CAP SCREW	***	A112162F
P108	M6 PENNY WASHER	***	W112151F
P109	M6 SPRING WASHER	***	W112251F
P110	M6 x 20 SOC HD CAP SCREW	***	A112202F
P111	M6 PLAIN WASHER	***	W112050F
P112	GREASE NIPPLE - 1/8" BSP	***	L120035P
P113	M6 x 12 SOC HD CAP SCREW	***	A112122F
P114	LIPSEAL	***	S361205P
P115	SPIRAL RETAINING RING	***	C110522P
P116	DEEP GROOVE BALL BEARING	***	A170202B
P117	LIPSEAL	***	S361256P
P118	SQUARE PAR. KEY	***	K180640P
P119	M6 LOCK NUT	***	N112050F
P120	M8 x 16 SOC HD CAP SCREW	***	A113162F
P121	M8 PLAIN WASHER	***	W113051F
P122	M8 SPRING WASHER	***	W113251F
P123	M12 NYLOC NUT	***	N115200F
P124	M12 PENNY WASHER	***	W115151F
P125	EYEBOLT M12 x 18	***	M115200F
P126	M12 x 85 TRUBOLT	***	W408014
P127	M8 HEX NUT	***	N113100F
P128	M10 x 50 HX HD BOLT	***	K114300F
P129	M10 PLAIN WASHER	***	W114050F
P130	M10 SPRING WASHER	***	W114251F
P131	M10 x 25 SOC HD CAP SCREW	***	A114222F
P132	M8 x 30 HX HD BOLT	***	K113240F
P133	LIPSEAL	***	S361302P
P134	RECT. PARALLEL KEY	***	K100840P
P135	M8 x 25 BUTTON HEAD SCREW	***	H113224F
P136	M10 HEX NUTS	***	N114100F
P137	M10 PLAIN WASHERS	***	W114050F
P138	M12 PLAIN WASHERS	***	W115050F
P139	M6 ST. STL. NYLOC NUT	***	N112200F
P140	M6 x 35 SOC HD CAP SCREW	***	A112262F
P141	M6 x 16 HEX SCREW	***	F112161F
P142	M30 PLAIN WASHER	***	W123051F
P143	M30 HEX HALF NUT	***	N123150F
P144	M20 HEX HALF NUT	***	N119150F

Dismantling & Assembly Diagrams

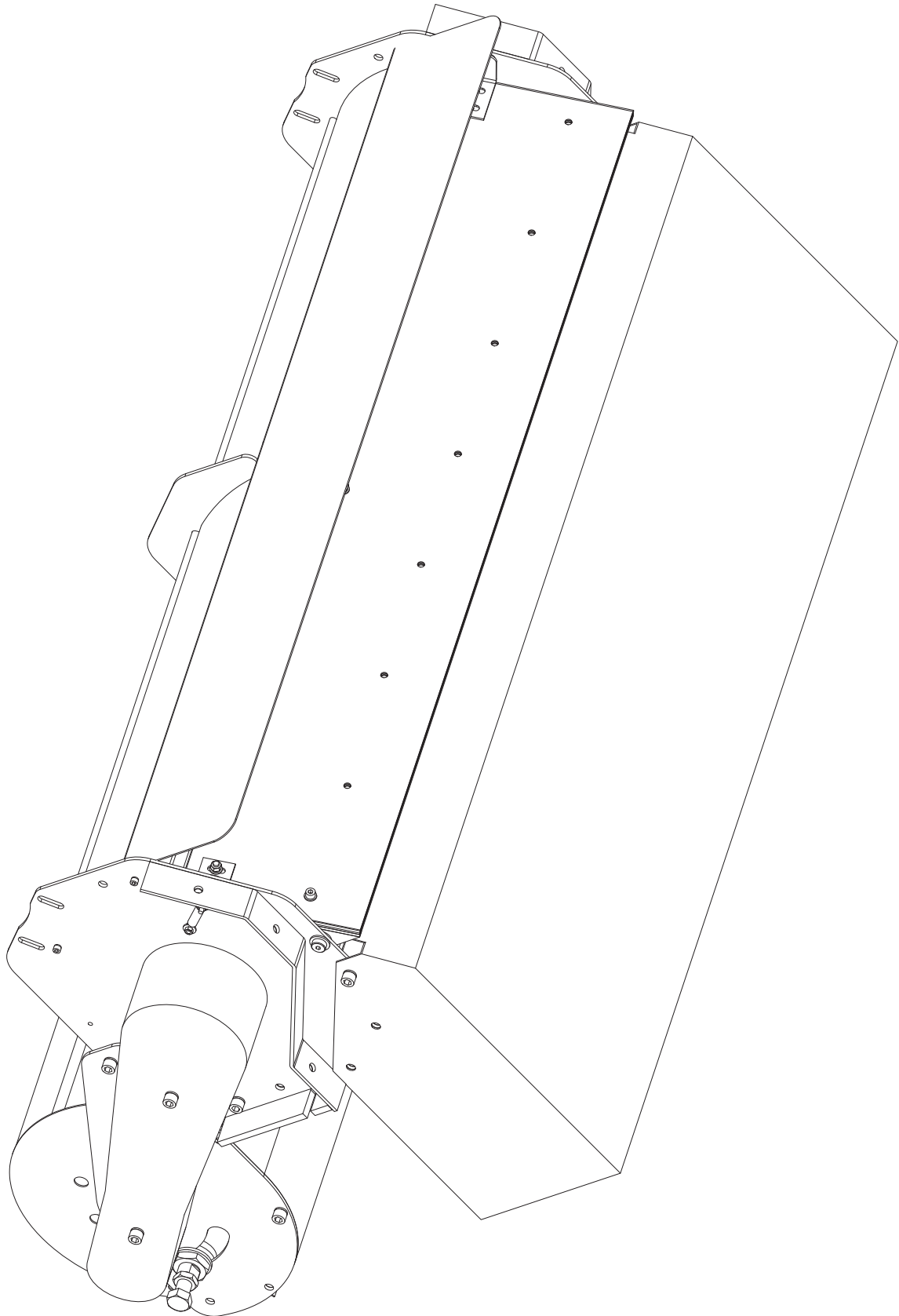

NOTE: ASSEMBLY PROCEDURE IS THE REVERSE OF THE DISMANTLING PROCEDURE SHOWN

Dismantling & Assembly Diagrams

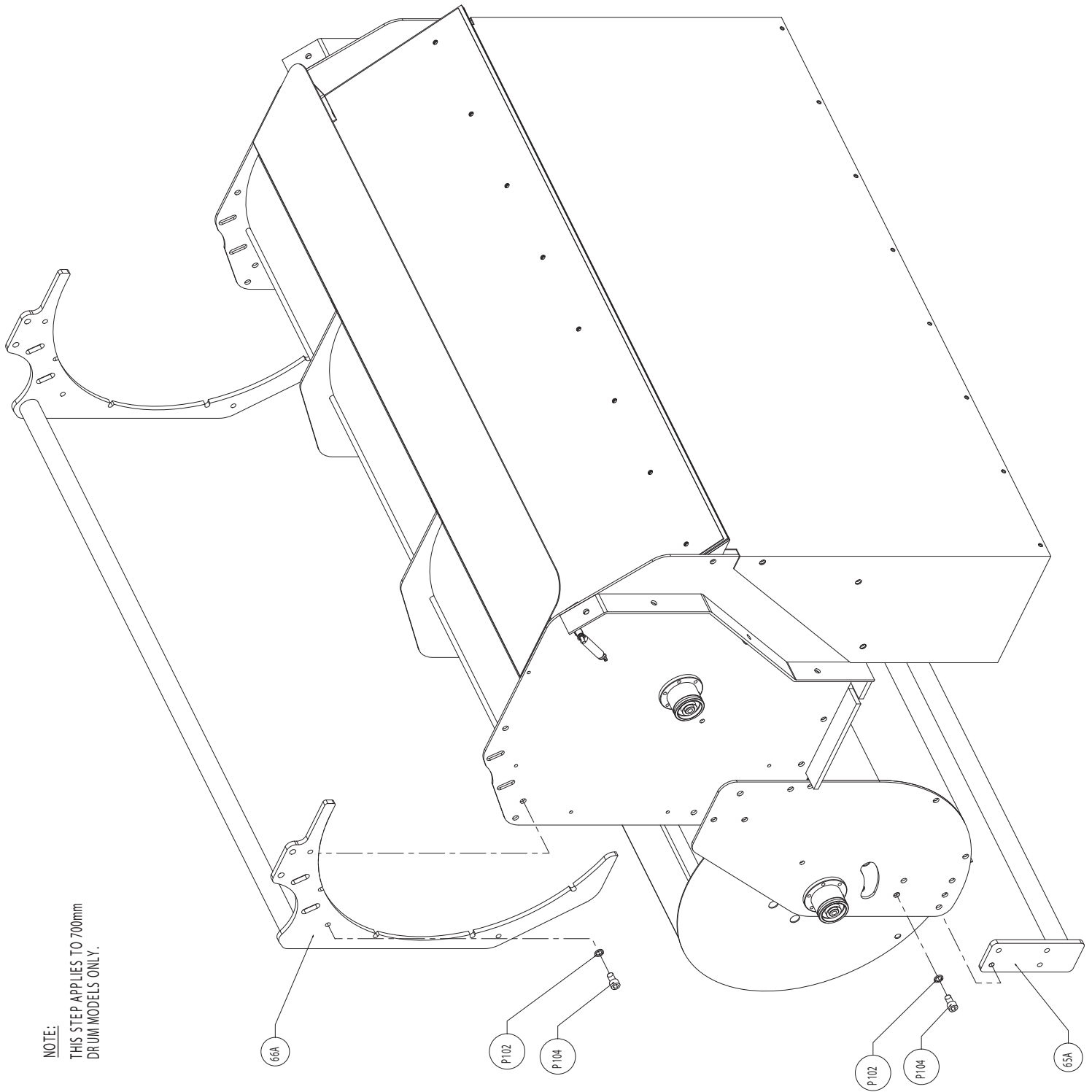

Dismantling & Assembly Diagrams

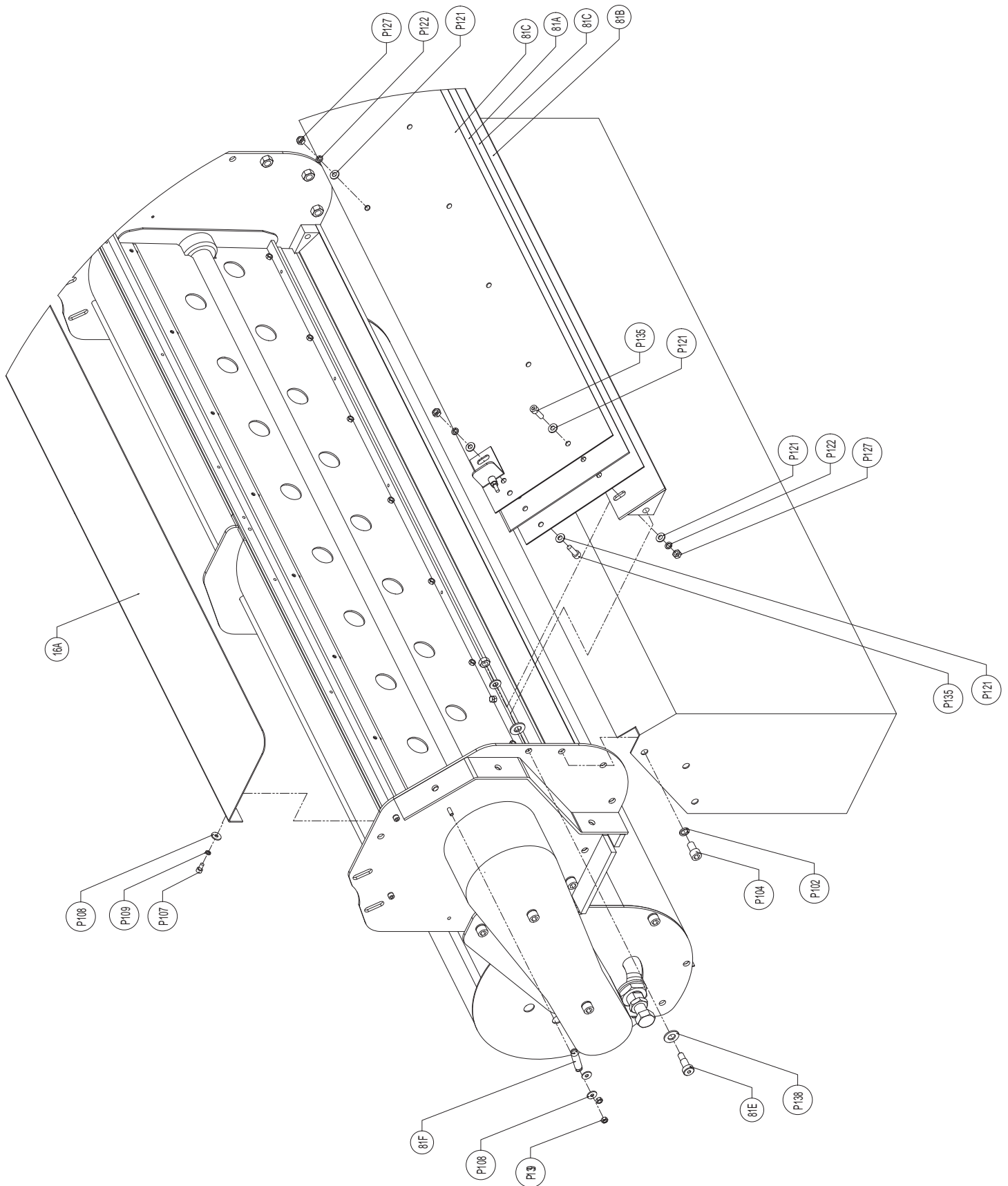

Dismantling & Assembly Diagrams

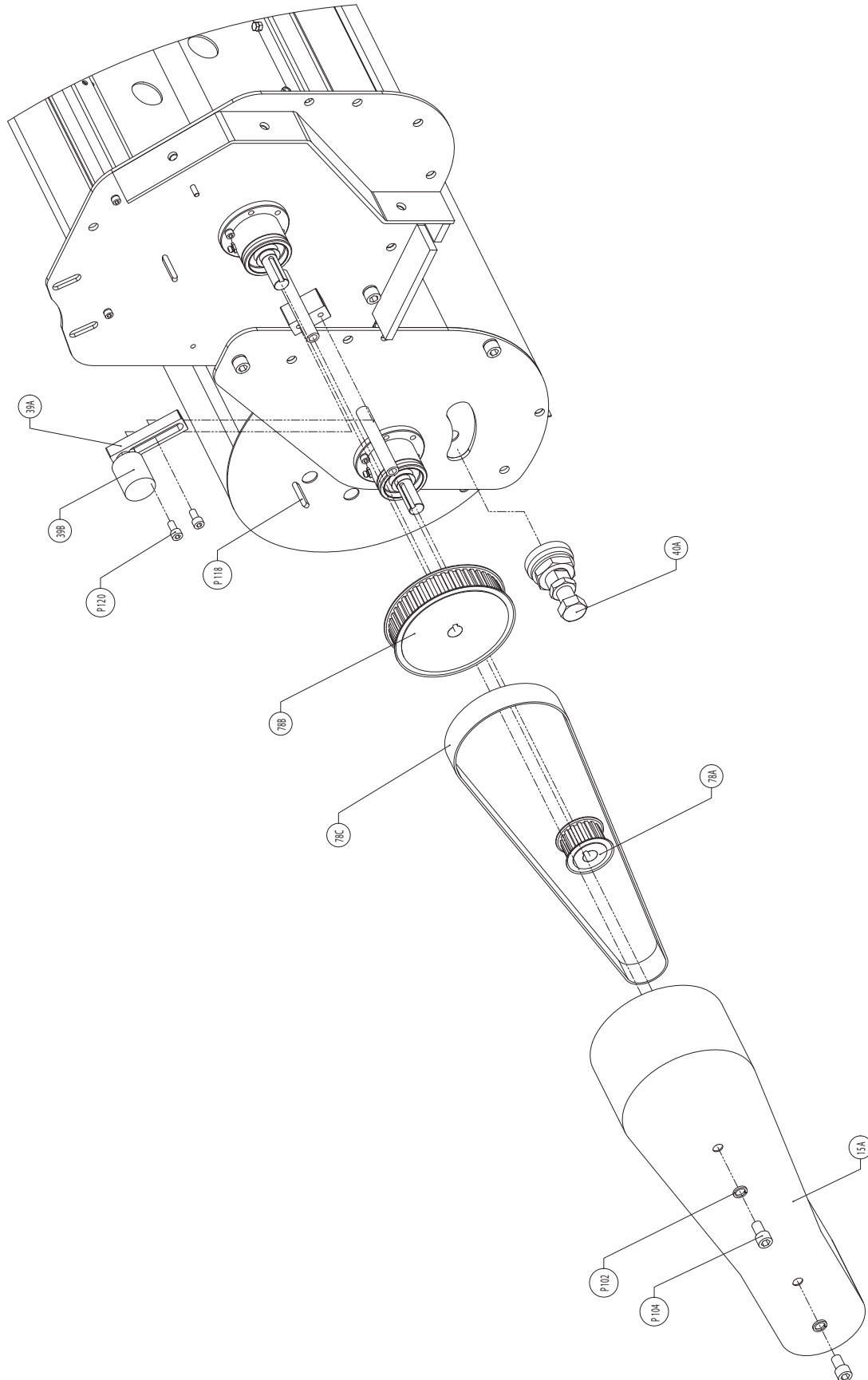

Dismantling & Assembly Diagrams

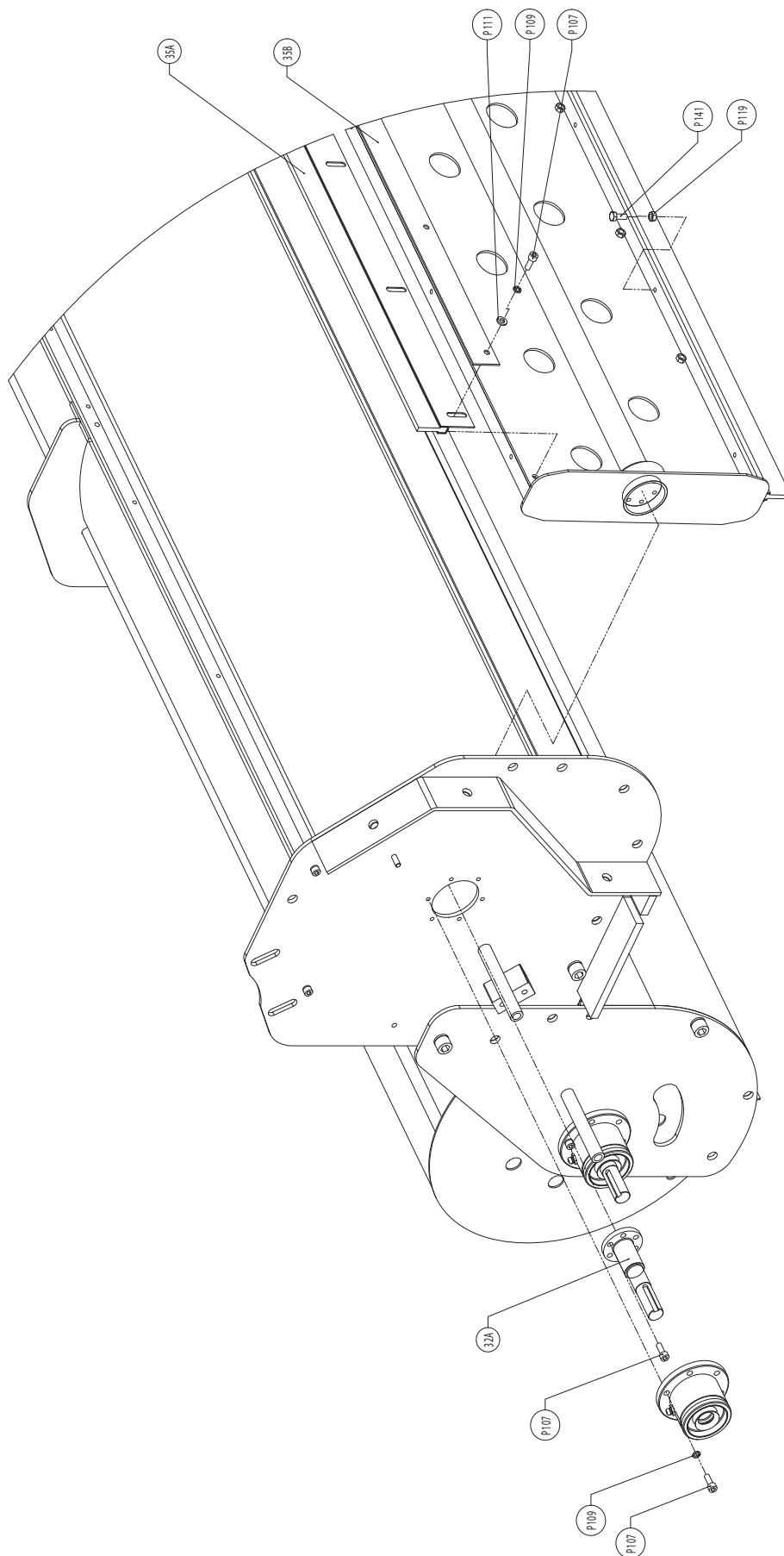

Dismantling & Assembly Diagrams

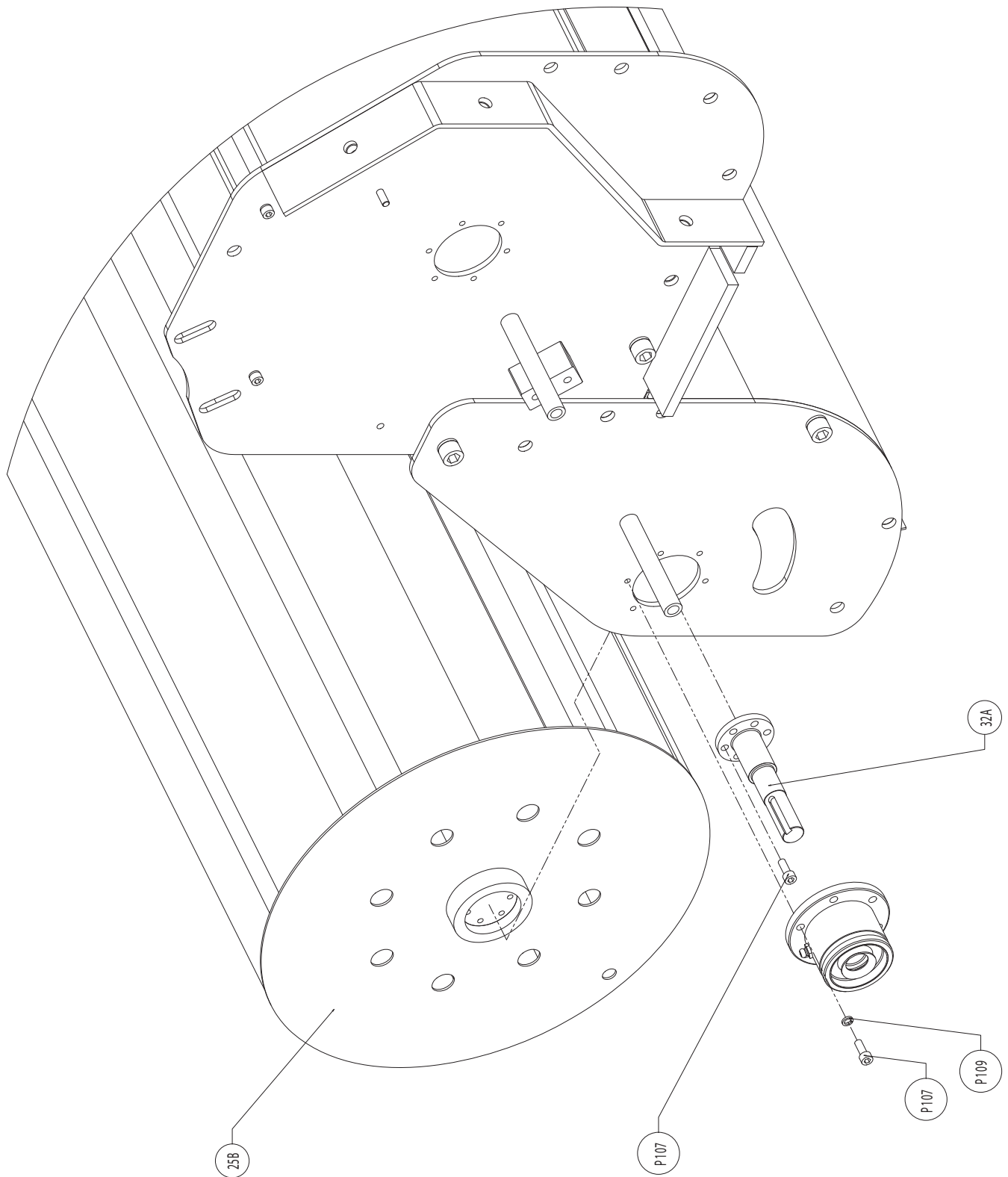

Dismantling & Assembly Diagrams

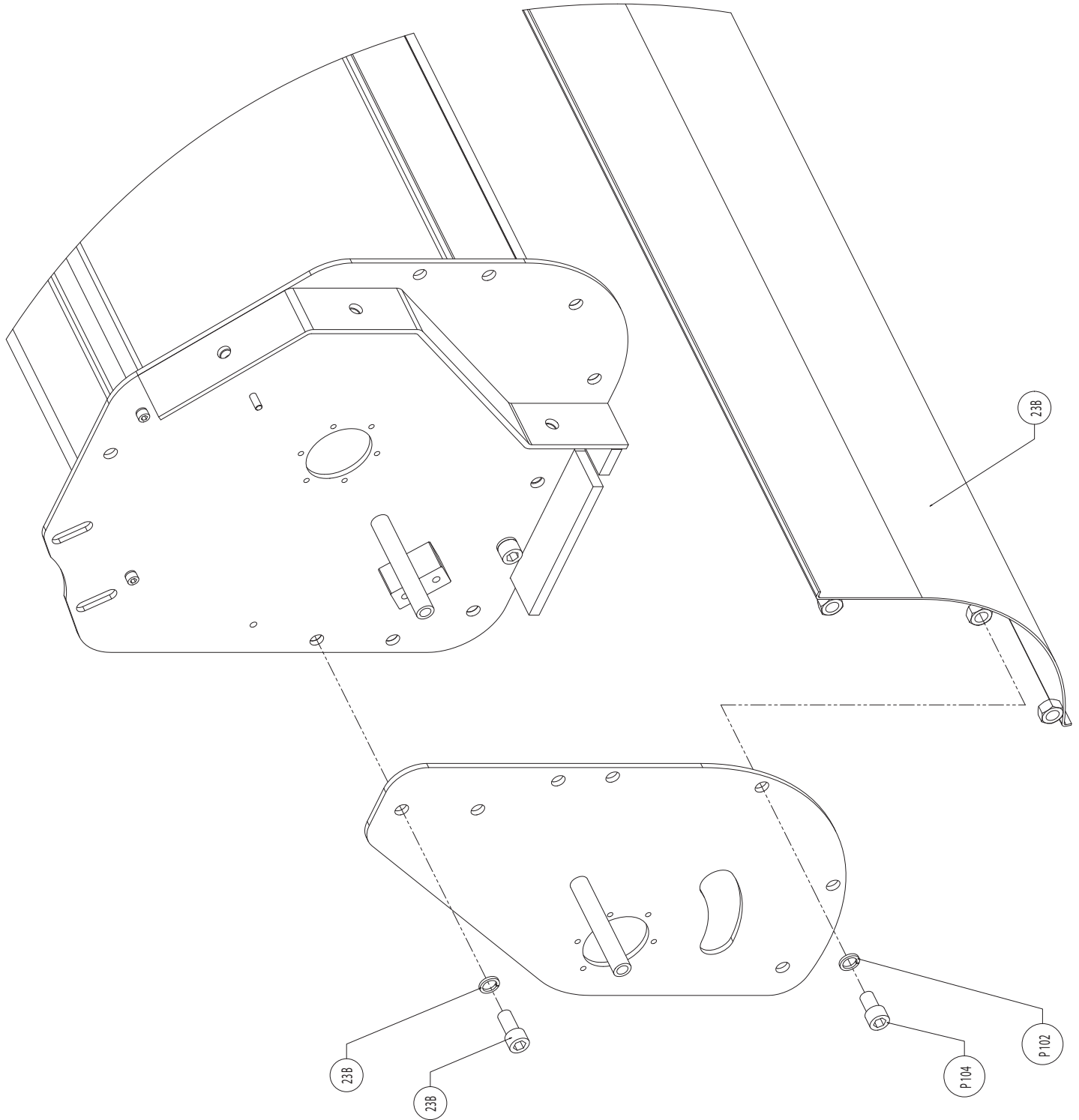

Dismantling & Assembly Diagrams

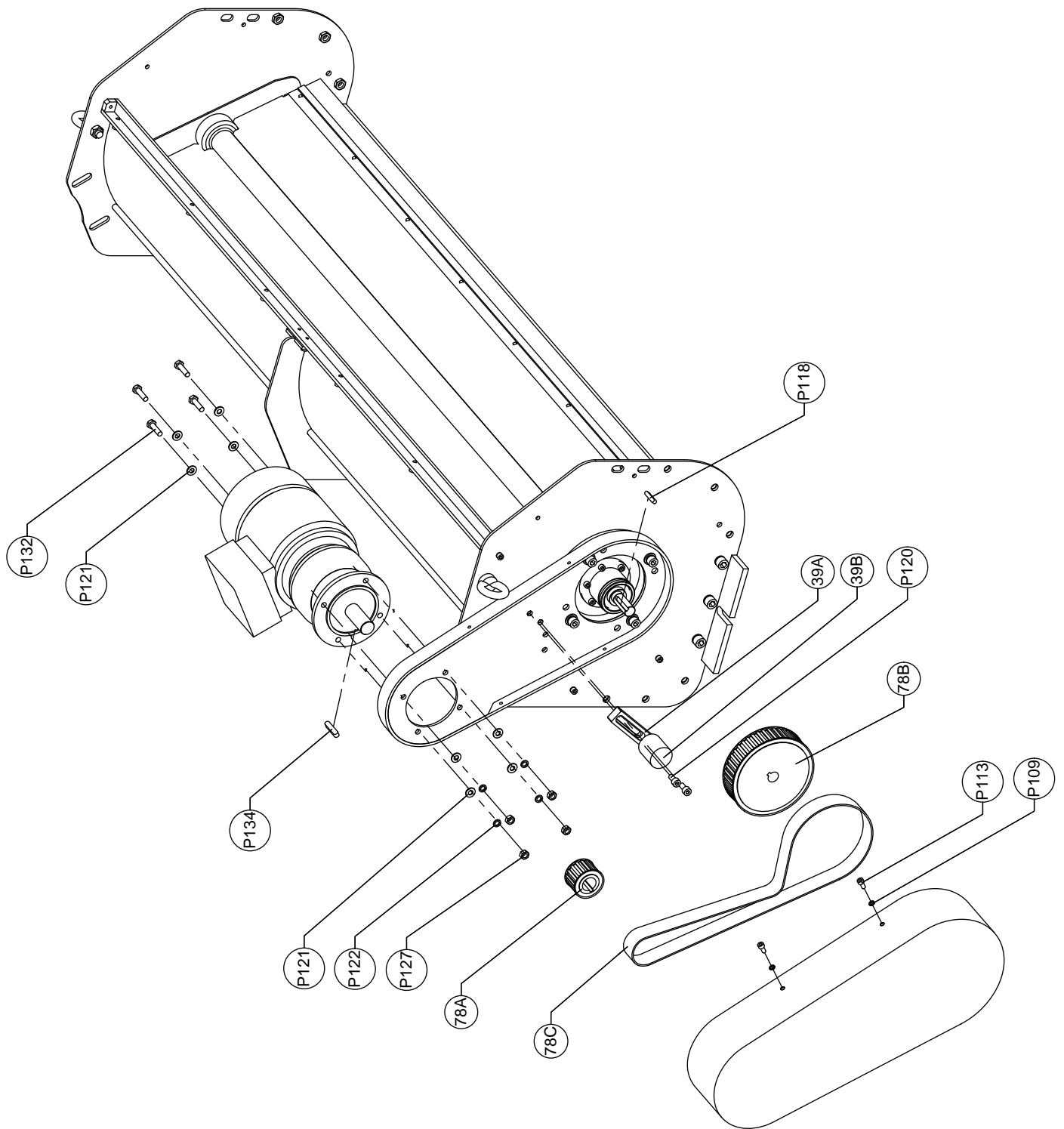

Dismantling & Assembly Diagrams

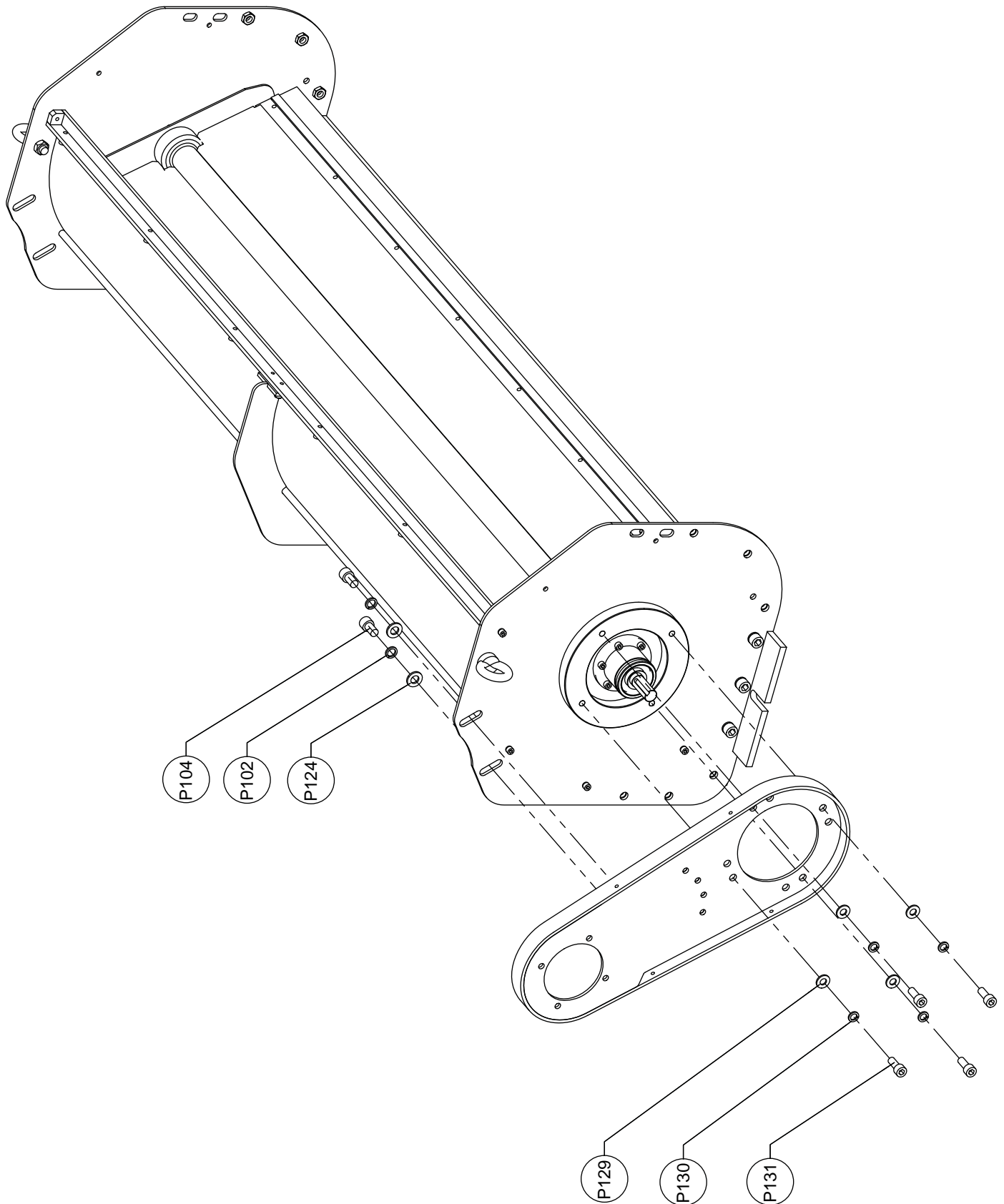

Dismantling & Assembly Diagrams

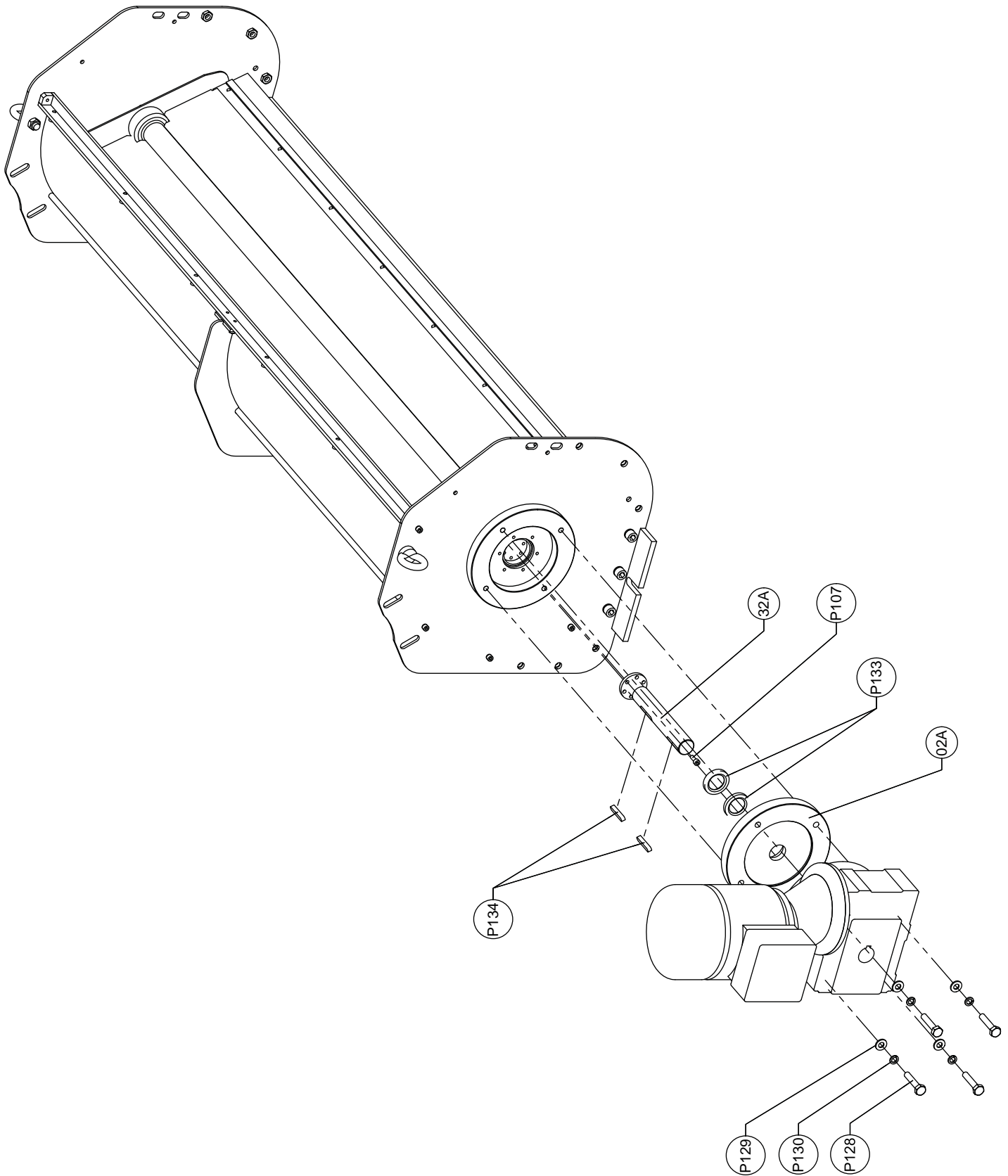

Dismantling & Assembly Diagrams

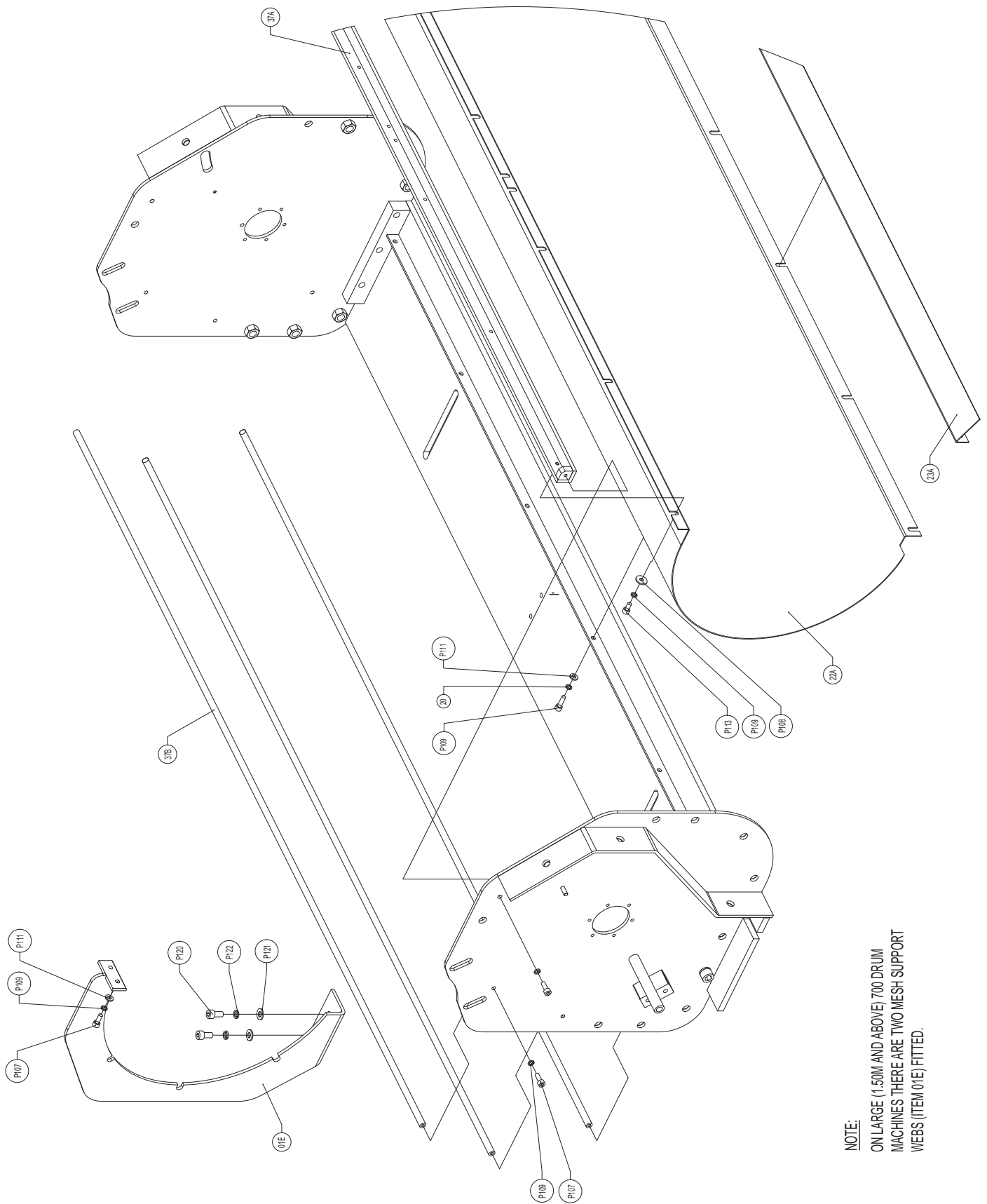

NOTE:
ON LARGE (1.50M AND ABOVE) 700 DRUM
MACHINES THERE ARE TWO MESH SUPPORT
WEBS (ITEM 01E) FITTED.

Dismantling & Assembly Diagrams

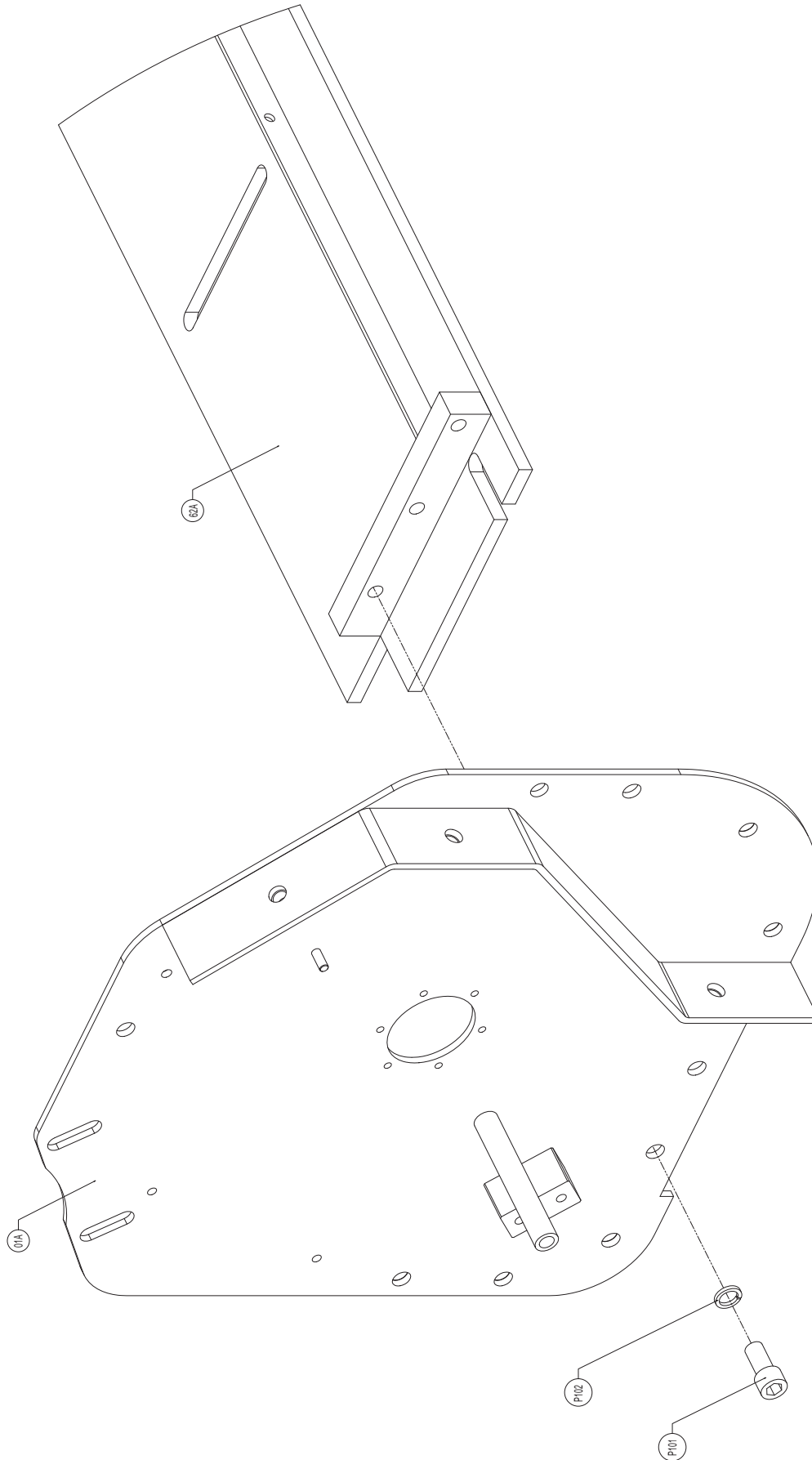

Dismantling & Assembly Diagrams

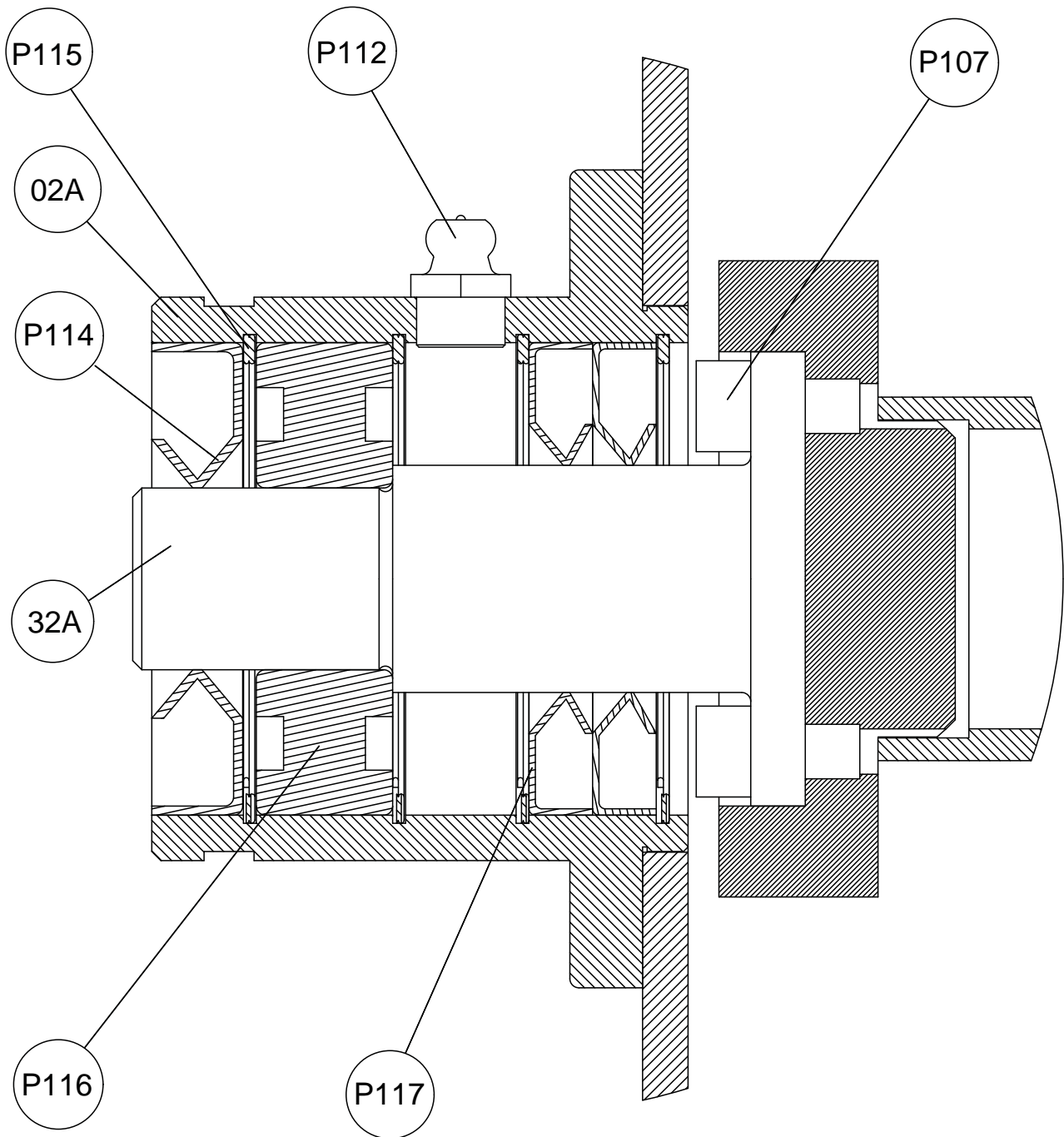

Europe

Mono Pumps Ltd, Martin Street, Audenshaw
Manchester, M34 5JA, England
T. +44 161 339 9000
E. info@mono-pumps.com

D.M.I EST, 56, rue du Pont
88300 Rebeuville, France
T. +33 3 29 94 26 88
E. dmi-est@dmi-est.fr

Americas

Monoflo Inc., 10529 Fisher Road
Houston, Texas 77041, USA
T. +1 713 980 8400
E. monoflo@nov.com

Monoflo S.A., Ing Huergo 2239
(1842) Monte Grande
Pcia. de Buenos Aires, Argentina
T. +54 11 4290 9940/50
E. info.monoflo@nov.com.ar

Monoflo Canada, 6010 – 53rd Ave
Alberta, Lloydminster
T9V2T2, Canada
T. + 1 780 875 5584
E: info.monoflo@nov.com

Asia

Mono Pumps Ltd, Building 5,
Madong Industrial Park, 1250 Sicheng Rd
Malu Town, Jiading District, Shanghai 201801
T. +86 21 3990 4588
E. monoshanghai@nov.com

Australasia

Mono Pumps (Australia) Pty Ltd
338-348 Lower Dandenong Road
Mordialloc, Victoria 3195, Australia
T. 1800 333 138
E. ozsales@mono-pumps.com

Mono Pumps (New Zealand) Ltd
35-41 Fremlin Place, Avondale
Auckland, 1026, New Zealand
T. +64 9 829 0333
E. info@mono-pumps.co.nz

Melbourne	T.	03 9580 5211	F.	03 9580 6659
Sydney	T.	02 8536 0900	F.	02 9542 3649
Brisbane	T.	07 3350 4582	F.	07 3350 3750
Adelaide	T.	08 8447 8333	F.	08 8447 8373
Perth	T.	08 9303 0444	F.	08 9303 4430
Darwin	T.	08 8931 3300	F.	08 8931 3200
Kalgoorlie	T.	08 9022 4880	F.	08 9022 3660
Christchurch NZ	T.	+64 3 341 8379	F.	+64 3 341 8486

www.monopumps.com



© Mono Pumps Limited September 2010 Literature reference: MPA604

Published information other than that marked CERTIFIED does not extend any warranty or representation, expressed or implied, regarding these products. Any such warranties or other terms and conditions of sales and products shall be in accordance with Mono Pumps Limited standard terms and conditions of sale, available on request.

Mono® is a registered trademark of Mono Pumps Ltd.

Registered in England No 300721

 **Mono®**

One Company, Unlimited Solutions