

1

2

3

4

5

6

7

8

A

B

C

D

E

F

G

H

DO NOT SCALE



FIRST ANGLE PROJECTION

IF IN DOUBT ASK

RENUMBERED FROM

MODIFICATIONS

- GDE.1. USE UP EXISTING STOCKS.
- GDE.2. ALTER EXISTING STOCKS
- GDE.3. EXISTING STOCKS TO BE PASSED TO SERVICE
- GDE.4. EXISTING STOCKS TO BE SCRAPPED

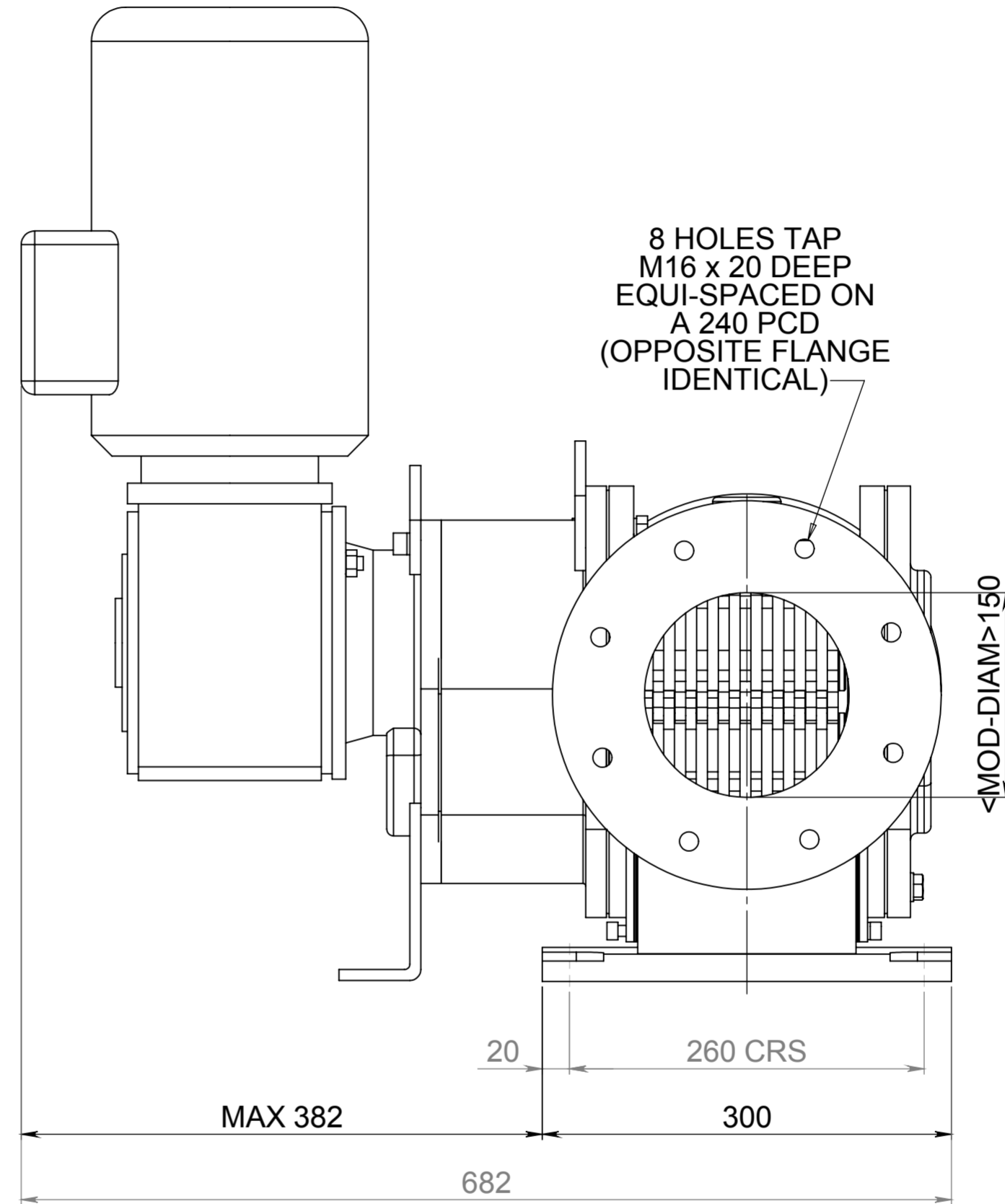
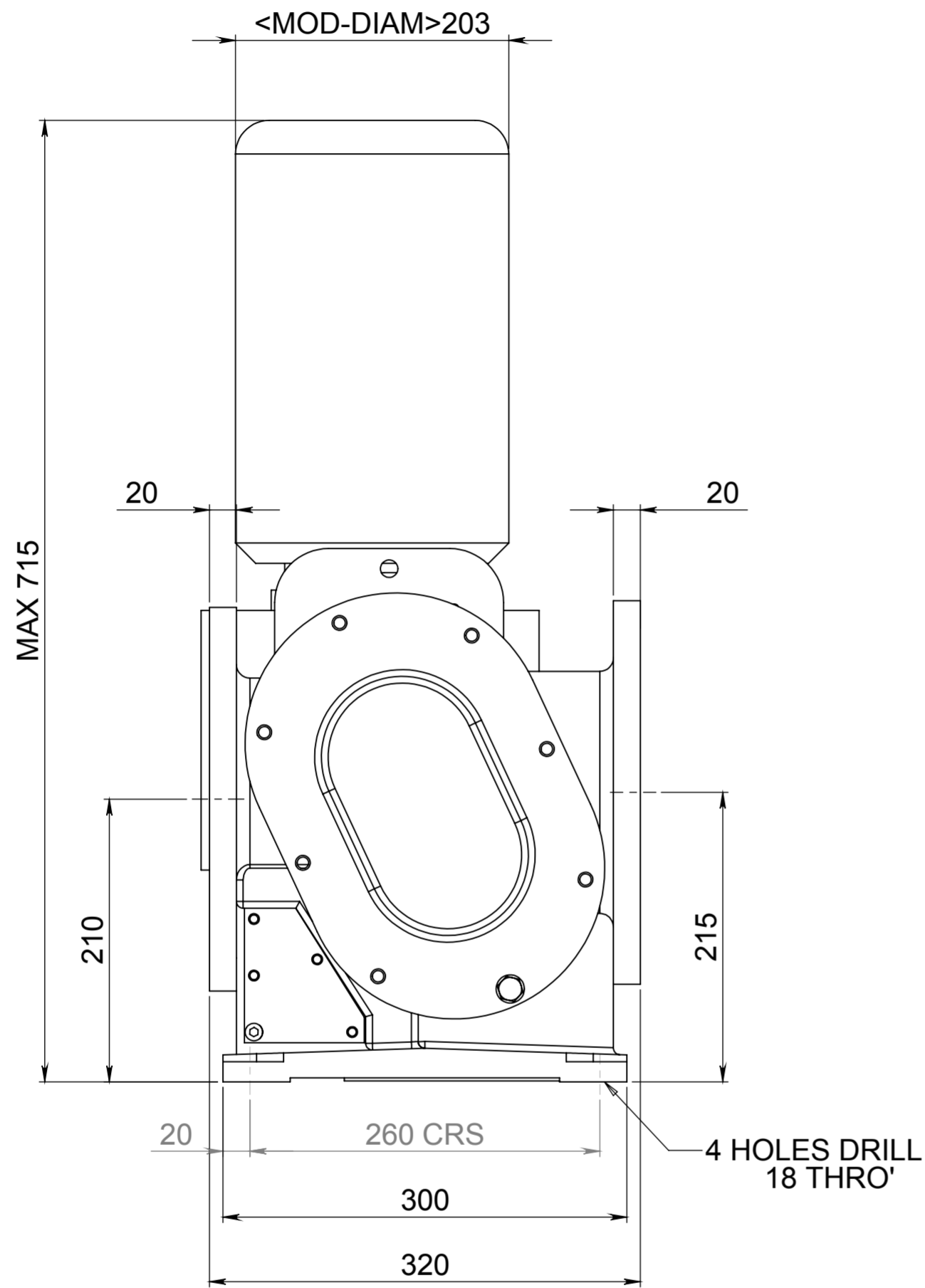

MODEL(S)	CT201D SK12080-100L/4	
SCALE	SHEET No.	ORIGINAL SPEC No.
1:4	1 OF 1	

"WARNING-THIS DOCUMENT CONTAINS MONO PUMPS LIMITED'S CONFIDENTIAL AND TRADE SECRET INFORMATION, AND IS GIVEN TO THE RECEIVER IN CONFIDENCE. THE RECEIVER ACCEPTS THE DOCUMENT IN CONFIDENCE AND AGREES THAT, EXCEPT WITH MONO PUMPS LIMITED'S PRIOR EXPRESSED WRITTEN PERMISSION, IT WILL (1) NOT USE OR DISCLOSE TO OTHERS THE DOCUMENT OR ANY COPY THEREOF OR THE CONFIDENTIAL TRADE SECRET INFORMATION CONTAINED THEREIN; (2) NOT COPY OR REPRODUCE THE DOCUMENT WHOLE, OR PART; AND (3) UPON COMPLETION OF THE NEED TO RETAIN THE DOCUMENT, OR UPON DEMAND, RETURN THE DOCUMENT, ALL COPIES THEREOF AND ALL MATERIAL COPIED THEREFROM."

STAMP COMPONENT WITH PART NUMBER IN POSITION INDICATED BY SYMBOL
 T.S.C. = THEORETICAL SHARP CORNER REMOVE ALL BURRS AND SHARP EDGES
 UNLESS OTHERWISE STATED ALL DIMENSIONS IN MILLIMETRES
 SCREW THREADS TO ISO METRIC COARSE MEDIUM FIT (H6 g6) BS3643.
 MACHINED DIMENSIONS 0.25mm.
 FABRICATED DIMENSIONS 2mm.
 HOLE CENTRES 0.50mm.
 ANGULAR TOLERANCE 1%.
 GENERAL ARRANGEMENT TOLERANCE 1%.

TITLE	GEN ARRANGEMENT				
SURFACE FINISH	N5	N6	N7	N8	N9
ROUGHNESS					
Ra μm	0.4	0.8	1.6	3.2	6.3
Ra μin	16	32	63	125	250

DRAWN	DEVANES	DRAWING No.	ISSUE
DATE	18/12/2008	T01D 9900	0
CHECKED			
DATE	01/01/2000		
WEIGHT	APPROX 175 KG		



AWAITING

A2