



English

Installation, Operation and Maintenance Instructions

Grifter

Packaged Pumping System

NOV Mono[®]

Contents

Section	Description	Page No.
Section 1:	Receipt of purchase & servicing details	1-2
Section 2:	Important Information regarding Disposal of Wastes into sewers	1
Section 3:	Warranty	1
Section 4:	Service, Installation & Spare Parts	1
Section 5:	Installation Instructions	1-3
Section 6:	Operation Instructions	1-2
Section 7:	Maintenance Instructions	1-3
Section 8:	Exploded Views & Spare Parts	1-2
Section 9:	Wiring Diagram	1-2
Section 10:	System GA Drawing	1
Section 11:	Pump Performance Curve	1

PLEASE READ THESE INSTRUCTIONS CAREFULLY BEFORE COMMENCING INSTALLATION

Receipt of Purchase

Receipt of purchase and servicing details

To the plumber, electrician and the householder.

Note: This folder must be left with the householder after completion of installation.

PURCHASING DETAILS

Customer Name: _____
Address: _____

Phone: _____

INSTALLATION DETAILS

Installed by Company Name: _____
Contact: _____
Address: _____

Phone: _____

UNIT DETAILS

Model No.: _____
Purchased From: _____
Purchase Date: _____
Serial No.: _____

PLEASE RETURN THIS PAGE TO:

Mono Pumps (Australia) Pty Ltd
PO Box 123
Mordialloc Victoria 3195
Attention: Marketing Department

IMPORTANT

INFORMATION REGARDING DISPOSAL OF WASTES INTO SEWERS

When connecting your premises to the sewerage system you should be aware of certain requirements of the NSW Local Government Act.

Your attention is directed to Clause 21 of Ordinance 46, which detail substances which are not to be deposited into the sewerage system. For your information these Clauses have been reproduced below. All the substances mentioned cause detrimental effects to the sewerage system and its operation.

In particular, items such as panty-hose, stockings, rags, bones, superwipes, sanitary napkins, wood, stone and metals cause major problems when they become entwined with impellers at sewage pumping stations and cause mechanical failure of pumps. Not only can such failures of pumps result in unsightly overflows they also involve high maintenance costs.

In addition, non observance of Clause 21(f) relating to roof drainage, etc., can result in overloading of sewer mains, inefficient sewage treatment and consequently high expenditure for remedial works, which is ultimately borne by the ratepayers.

EXTRACT FROM ORDINANCE 46 SUBSTANCES EXCLUDED FROM SEWERS

21. Except as may be otherwise provided by this Ordinance a person shall not throw, deposit or discharge, or cause, permit or suffer to be thrown, deposited, or discharged into any sewer of the Council or into any sewerage service communicating directly or indirectly with any sewer or Pumping Station of the Council, or into any sanitary fitting used in connection with such sewerage service any of the following substances:-

- (a) Any animal matter (other than the wastes of the human body), wool hair, fleshings, grease, dust ashes, cinders, soil, rubbish, filth, oil, salt, mud, sand, gravel, garbage, offal, dead animal, vegetable or fruit parings, rags, house refuse, steam or any solid matter.
- (b) Any petrol, or any other inflammable or explosive substance whether it be of a solid, liquid or gaseous nature.
- (c) Any infectious or contagious solid or liquid substance.
- (d) The contents of any night-soil cart, cesspool, or privvy.
- (e) Any wastewater or other waste liquid which contains such percentage of common salt or any other mineral salt, acid or gas, or is at such temperature as is in the opinion of the Council injurious to, or liable to form compounds injurious to any part of the sewerage system or treatment works or to employee of the Council engaged in the operation or maintenance of same.
- (f) Any roof, rain, surface, flood, seepage, or subsoil water.
- (g) Any other substance which in the opinion of the Council is likely to affect injuriously the sewerage system or employees of the Council engaged in the operation or maintenance of the same.

Penalties for contravening these regulations are severe.

Warranty

1. Pumps manufactured by Mono Pumps (Australia) Pty Ltd are covered by warranty for a period of twelve months from installation.

2. Mono Pumps will make good by repair, or at their option, the replacement of faulty parts under warranty, providing always that:

- The equipment was correctly installed and properly used in accordance with Mono Pumps Installation and Operating Instructions and accepted codes of good engineering practice.
- Any claim under warranty arises solely from faulty design, material or workmanship.
- Repairs are carried out with the written approval of Mono Pumps (Australia) Pty Ltd who may choose to carry out the repair themselves or at their option nominate an approved repairer for the purpose.
- All costs other than the direct repair costs are borne by the purchaser.

3. Auxilliary equipment not of Mono Pumps manufacture but supplied by Mono Pumps as part of a package will be protected by the original manufacturers warranty. Mono Pumps warranty is limited to that extent.

4. Mono Pumps warranty does not cover any of the following:

- Claims for third party liability for damage caused by the failure of any of the company's products.
- Damage caused by abnormal operating conditions, war, violence, storm cataclysm or any other force.
- Damage caused by the equipment being used for an application for which the product is not recommended.

5. The decision of Mono Pumps in relation to any claims or disputes over warranty is final.

6. The warranty is in lieu of all other warranties and conditions expressed or implied, written or oral, statutory or otherwise, which are hereby negated and excluded.

7. This express warranty does not exclude any conditions of warranty implied by the Trade Practices Act 1974 or separate State laws and is in addition to any other right that the original purchasers or any subsequent purchaser may have at law.

The equipment covered by this warranty is supplied under the conditions detailed in Mono Pumps (Aust) Pty Ltd "Conditions of sale" which should be read in conjunction with the statements herein.

In the case of claim please contact your Authorised Mono Pumps Dealer or contact Mono Pumps (Australia) Pty Ltd direct with details.

Spare Parts

SERVICE

Mono Pumps (Aust) Pty Ltd can provide prompt after sales service and spare parts to suit your requirements:

Head Office:
338-348 Lower Dandenong Road Mordialloc Vic 3195
Telephone: (03) 9580 5211
Fax: (03) 9580 9036
Contact: Internal Sales Engineer

or

Cnr Ethell & Marshall Roads Kirrawee NSW 2232
Telephone: (02) 521 5611
Fax: (02) 542 3649
Contact: Internal Sales Engineer

Spare Parts

1. INSTALLATION INSTRUCTIONS

Note: The Mono Grifters® are designed to handle normal domestic sewage and, whilst they will tolerate reasonable quantities of paper and rag etc., economical life of essential components will be reduced should, for instance, sink grinder waste containing glass, bone and metal scouring pads enter the tank. Care should also be taken to eliminate wet strength, padded nappies and condoms from a Grifter system. In addition, surface water should also be excluded from the system.

Under no circumstances should a Grifter be installed where it will be subject to flooding.

1.1 Position of Unit

It is important that before civil work starts, an investigation of the selected site is made, through which the water table and nature of ground can be established.

These factors together with the invert level for the incoming sewer line will have some influence on the depth at which the unit is finally positioned but care must be taken to ensure that neither buoyancy nor damage to the electric motors can occur through possible flooding.

An excavation should be prepared to the following approximate dimensions 1100 x 1100 x 1300 deep. Fill sand or road metal dust should be placed in the bottom of the excavation and compacted to a thickness of approximately 200mm. This will provide an adequate foundation on which to place the tank.

NOTE: Mass concrete ballast and backfill may be required in water charged ground conditions. The services of a suitable qualified engineer should be sought in such circumstances.

The tank should rest firm and level on the base and after all the incoming pipework has been connected, stability can be achieved by back filling and compacting around the sides of the tank with fill sand.

NOTE: IT IS MOST IMPORTANT HOWEVER THAT THE INCOMING SEWER PIPE DOES NOT ENTER THE TANK ADJACENT TO THE FLOAT SWITCH.

Whilst the totally enclosed electric motors and associated wiring will tolerate an occasional damp environment, none of the Grifters are designed to operate partially or fully submerged. Furthermore the Mono Pump Grifter must not be installed in a sealed chamber unless adequate precautions are taken to minimise condensation through the use of continuous forced ventilation or other means. Subject to free natural air movement and protection from frost and driving rain etc., the Mono Grifter® will give reliable and economical service.

1.2 Connection of Incoming & Suction Pipework

It is recommended that the incoming sewer pipe and the emergency overflow pipe (if required) protrude into the tank by approximately 60mm. Holes for the pipes should, if possible, be cut in the flat sections of the tank and sealed with a suitable grade of Denso Mastic or epoxy cement. The inlet pipe should not be sited adjacent to the float switch. (Refer Section 10 - Drawing No. Grifter DSP1).

Alternatively polypropylene or similar couplings to suit specific pipe materials can be obtained direct from the Manufacturers or through builders merchants. If in doubt, however, guidance on accepted practice should be obtained from the local authority concerned. After cutting the holes, care should be taken to remove any pieces of GRC which may have fallen inside the tank. An 80NB PVC should be solvent cement jointed to the PVC socket which protrudes through the baseplate at the suction end of the Grifter unit.

The distance between the sump floor and the bottom of the suction pipe should be approximately 100mm.

Spare Parts

1.3 Connection of Delivery & Vent Pipework

The delivery pipework should be connected to the pump discharge port in accordance with accepted Engineering practice. It is important, however, to install the following items in the discharge pipework at close proximity to the pump:

- (a) A pressure gauge connection in the form of a plugged TEE.
- (b) A swing check non return valve.
- (c) A gate (isolating) valve with handle below the pipe.

To facilitate future maintenance, provision for easy dismantling of pipework should be made by installing a union joint or Malco coupling in the pipework somewhere between the gate valve and the pump discharge port. Where required, connect a suitable tank vent pipe or elbow to the top of the baseplate.

Note: All pipework should be independently supported so as not to place undue stress on pump discharge port.

1.4 Electrical Connections and Float Switch Settings.

Wire control panel as per wiring diagram inside cabinet (refer Section 9: Drawing No. Mono 013).

1.4.1 Two Float Switches

Connect float switches with low level being 910mm (36") from underside of Grifter base to cable inlet on ball, high level being 460mm (18") from underside of Grifter base to cable inlet on ball.

1.4.2 Single Float Switch

(See sketch on following page (page 3)).

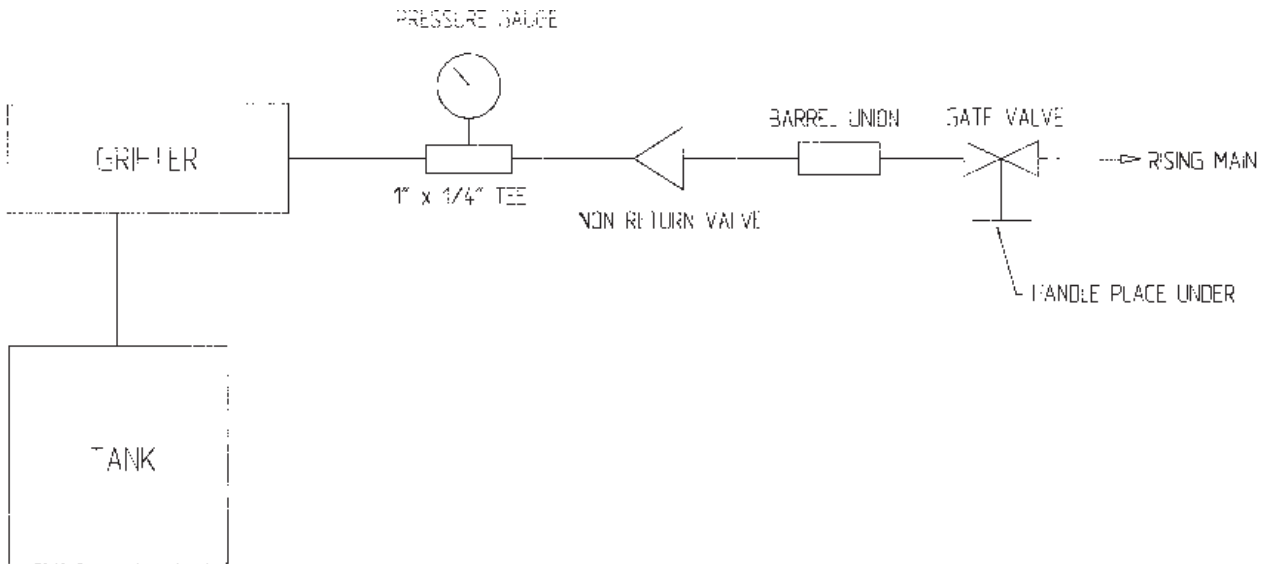

Spare Parts

MAC-3 Ball Float Switches

Applications

- high and low alarms
- pump or differential level control

The Mac-3 ball float switch is cable suspended and is suitable for use in all vessels containing water and mild inert solutions.

Wash-down applications.

The PVC cable and Moplen switch housing is resistant to water based wash down solutions containing less than 3% of most inorganic acids and bases including; chloric, sulphuric, phosphoric, nitric, chromic caustics, potassiums, ammonium hydroxides, nitrates, and sulphates etc., at temperatures of less than 50°C.

The Mac-3 is also suitable for use in washdown solutions containing fuel oil, oil, grease and other hydrocarbons within the limits mentioned above.

Temperature limits:	-25 to +80°C
Float shell material:	Moplen
Float shell diameter:	105mm
Cable:	3 core PVC sheathed
Cable lengths:	2, 5, 10, 15, & 20 m
Contracts:	SPCO Microswitch 15A 240 Vac resistive
Electrical life:	100,000 operations at full load.

Discharging

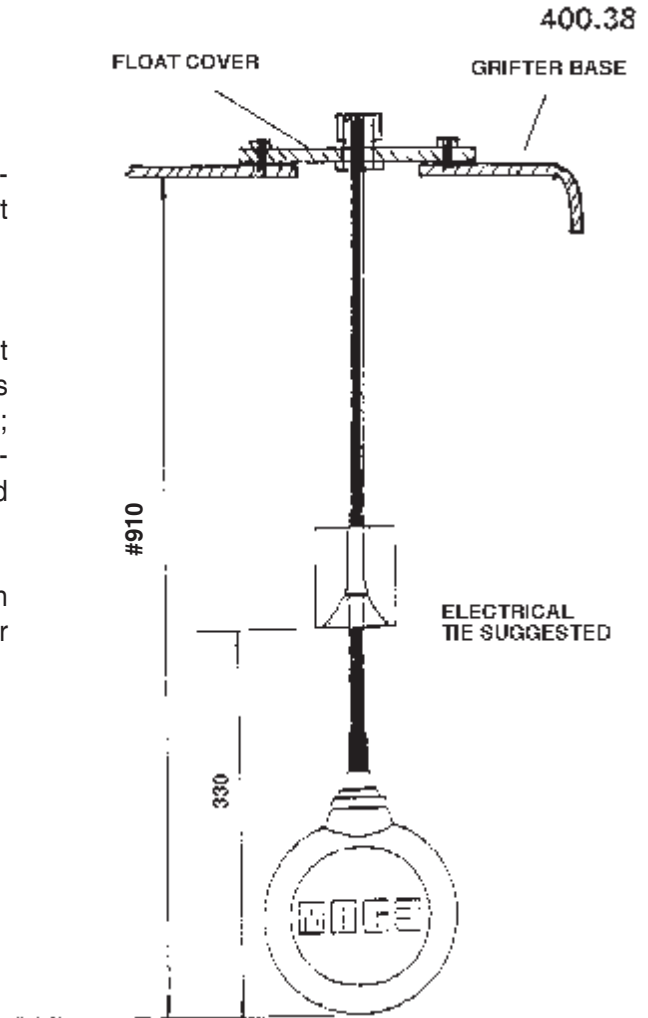
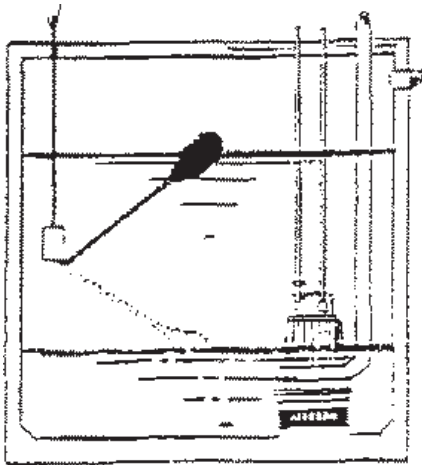

#Standard float set up height for single piece tank. If optional tank riser used, height becomes 1560.

Operation

2. OPERATING INSTRUCTIONS

2.1 Starting the Equipment

IMPORTANT: Fill the pump with water before starting - never run the pump dry. Immediate damage to the pumping element will be caused if the Grifter unit is allowed to operate without liquid in the pump or tank.

The plug on the top of the end cover of the pump may be used for filling purposes. This should be removed and the pump filled with water, after which the plug should be replaced, taking care to avoid air leaks by the use of a suitable jointing compound or thread sealing tape. This procedure is only necessary on initial start-up or after draining for maintenance or other purposes. It is most important that the gate (isolating) valve on the pump delivery pipe is fully open and that there is at least 200mm (8") of liquid in the tank. The Grifter can now be started by selecting "Manual" on the control box. Hold switch closed to test.

Check immediately that the Grifter is running. If the unit is working correctly switch to auto. Maintain the test run period by opening household water taps and check for connections. Check that the (bottom) float switch stops the unit at low level and that approximately 180-200mm of liquid is retained in the tank. The unit is now ready for normal, fully automatic use.

2.2 Fault Finding

Static or increasing liquid level

This would suggest one, or a combination of the following:

- (a) overload tripped
- (b) restriction in the vertical suction pipe or macerator
- (c) restriction in the check valve or delivery pipeline
- (d) damaged pump element
- (e) movement of float switch restricted at high level

(f) damaged mechanical seal in the macerator. Having checked the control fuse, freedom of float switch and direction of rotation, the total discharge pressure should be checked by fitting a reliable pressure gauge to the discharge line. Should the reading substantially exceed the calculated total head or the maximum design pressure for the pump (28m or 40 psi) stop the unit immediately and make certain that the check valve and remainder of delivery pipe is free of obstruction. Should no restriction or blockage be found and having determined that the pressure is below the designed rating for the pump, contact your Mono® service agent.

NOTE:

Pump output is directly proportional to speed. Should a static liquid level in the tank be observed in conjunction with no recorded discharge pressure, stop the pump immediately as this would suggest a blockage in the suction pipework or macerator or connecting pipe between the pump and macerator.

The suction pipe can be cleared by removing the plug 'D' and rodding the pipe. Once clear, the plug should be replaced using PTFE or a similar sealing medium to prevent leakage.



Time can be saved by fitting a reliable vacuum gauge to the pump priming connection on the suction side as in the event of restriction this will immediately be revealed by a reading well in excess of approximately 3" HG (76mm HG) which can be taken as an average figure for normal use in conjunction with a fibreglass tank.

Operation

Unit fails to stop at low level

Check movement of low level float switch and hose down inside of tank, ensuring that all accumulated solids on the float switch body, cable and tank bottom are pumped away or manually removed if these are likely to cause damage to the macerator or pump.

2.3 Holding Tank Details

Total capacity (full)	= 700 litres
Working capacity (between high/low level)	= 450 litres
Tank weight (empty)	= 90 kg

Maintenance

3. MAINTENANCE INSTRUCTIONS

3.1 General

Subject to correct installation the Grifter will give reliable and economic service providing no solids other than those normally associated with domestic sewage enter the tank.

Take care to replace all components which show signs of wear or damage. Examine oil chamber sight glass for oil level. If oil is absent this would suggest mechanical seal failure. In particular, closely examine the mechanical seal on the macerator, the cutter ring, the impeller, the pumping element and mechanical seal. As a general guide the scroll of the Stator should be well profiled and smooth. In the event of internal roughness or splitting a new component must be fitted. Similarly the rotor scroll should be well profiled with a surface free of damage. Whilst a rotor with minor surface scouring could be serviceable where low discharge heads appertain, it should be remembered that without an interference fit between rotor and stator, maximum pumping efficiency cannot be obtained.

3.2 Float Switch

The float switch supplied needs no maintenance except to ensure that it does not become coated with paper, rags grease etc., which will impair its operation. It is therefore important to check the float switches every six to eight weeks, at which time the floats, float cables and tank walls should be hosed down with clean water. The tank should be filled with clean water to the high float level and with the system in auto this will start the unit and allow it to flush the discharge. As the float switches are sealed units any failure to same will necessitate replacement.

3.3 Grifter Unit

SWITCH OFF AND ISOLATE MAINS POWER SUPPLY BEFORE SERVICING

Removal (refer drawing Section 8 Page 2)

- Having ensured the electrical supply to the unit has been isolated, remove the motor terminal cover and disconnect the supply cable making due note of the number and connections.

- Disconnect the inlet casing (23) by removing the bolts and washers (24, 25, 30) and O ring seal (5).

- Disconnect the discharge pipework at the nearest point to the pump outlet.

- Remove nuts from the motor mounting plate and move the Grifter to a suitable position for maintenance and servicing.

Replacement:

- Replace unit in position and secure with motor foot mounting bolts.

- Reconnect in reverse to 1-4 above.

- Switch on electrical supply and test run unit.

3.4 M12 Macerator

Disassembly (refer drawing Section 8 Page 2).

Replacing Cutter Ring:

- The cutter ring (2) can be gently eased out of the macerator body (1) using a lever.

- The cutter ring can then be inspected for wear and replacement if necessary.

Replacing Impeller:

- Remove the locknut (9) and washers (7, 8). (Locknut is left hand thread).

- Remove the impeller (4) from the shaft complete with brass washer (6) and inspect for wear or damage. Screw 2 x M10 screws into impeller to help remove.

Maintenance

Replacing Mechanical Seal

- Remove the oil bath drain plug (31) and drain oil.
- Remove the seal retaining boss (11). (Note: This has a right hand thread) and sealing washer (12).
- Remove the rotating part of the seal complete with pressure spring from the shaft sleeve (22).

The static seal face can be carefully withdrawn from the recess in the retaining boss for inspection.

Replacing Rear Oil Seal & Seal Sleeve

- Remove motor to body retaining hardware (15, 16, 17, 19).
- Carefully extract the macerator body (1) taking care not to damage the shaft.
- Oil seal (20) can now be carefully removed for replacement.
- The seal sleeve (22) can now be replaced if necessary by removing the grub screw (27) and pulling-off the sleeve.

Assembly

- Fit 'O' ring (26) and key (32) to the motor shaft.
- Push on new sleeve (22) and lock into position with grub screw (28) and fit thrower (21) onto larger diameter of sleeve. Do not push the sleeve fully home, align the end of the sleeve with the lower edge of the chamfer

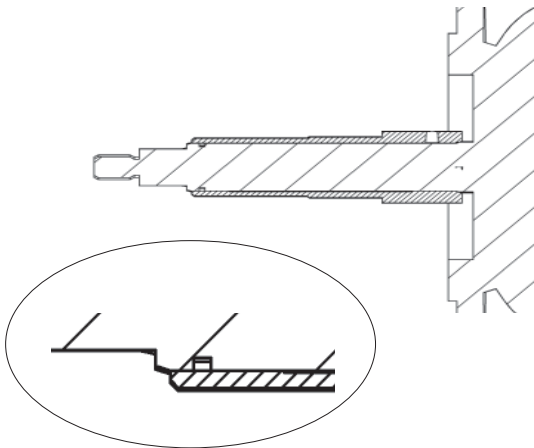

see diagram below

- Press oil seal (20) into macerator body ensuring garter spring faces recess.
- Carefully fit the body onto the motor flange ensuring that no damage occurs to the oil seal (20) and fit all retaining hardware (15, 16, 17, 19).
- Fit the rotating element of the mechanical seal to the shaft sleeve and ensuring that the recess in the static race lines up with the pin within the retaining boss, fit the retaining boss (11) and seal (12) using a sealant/adhesive compound such as Stag A on the retaining boss thread.
- Fit the impeller (4) and retaining hardware (7, 8, 9). The impeller locknut (9) should be tightened to a torque of 52nm. Finally fit the nut cap (10).
- Place the 'o' ring (3) into the groove on the outside of the cutter ring (2) and carefully press the cutter ring into the main body (1). Ensure o-ring and groove have been oiled.
- Fit the end cover (23) and 'O' ring (5) using retaining hardware (24, 25, 30).
- Ensure oil bath plug is tightened correctly and fill with oil until lever can be seen half way up the sight glass (28). Refit filler plug and seals (14, 17, 18).

3.5 Pump (Mono CP25)

Disassembly (refer Section 8 Page 1).

Removal of Stator:

Undo the eight nuts (8) and remove bolts (7) to release the end cover (1). Remove end cover and stator support ring (13) complete with 'o' ring (11). The stator may now be removed.

Removal of Rotor:

Holding the end of the motor shaft with the special spanner, place a second spanner on the flats of the rotor. By rotating anti-clockwise, the rotor may be removed,

Maintenance

taking care that the mechanical seal is not damaged. Should the stub shaft (12) come away with the rotor, it may be separated by turning in opposite directions as stated in previous paragraph, holding the stub shaft with a spanner on the flats provided.

Note: Separate stub shafts are only fitted on grifters using Crompton motors.

Removal of Mechanical Seal:

This component is entirely self-adjusting in service and needs no maintenance. Removal of the rotor (4) either with or without the stub shaft (12) will release the moving parts of the mechanical seal which may then be slid off the stub shaft. To remove the static seat of the mechanical seal, undo the four nuts at the motor/body flange and remove the bolts and washers. The body (5) may then be removed from the motor. Care should be taken to ensure the static seat does not touch the shaft. After removing the body from the motor, the static seat may be removed by hand from the body.

Assembly

Stub shaft, mechanical seal and body:

Screw stub shaft (12) onto motor shaft (ensuring that it screws up the full distance, hard against motor shaft shoulder). Tighten in position. On newer models (using CMG motors) the stub shaft is integral with the motor shaft. Replace static seat of mechanical seal (6) in body (5). Ensure that working face is exposed. Pass body and static seat over stub shaft and engage body flange on motor flange spigot. Do not allow static seat to touch stub shaft. Ensure that bolt holes are aligned, enter bolts, screw on nuts with washers and tighten in position.

Rotor:

Pass moving half of mechanical seal along stub shaft. Holding the spring locating washer, enter the rotor onto the stub shaft. Ensure that the spring locating washer is not caught between rotor and the stub shaft. Tighten rotor in position.

Stator and end cover:

Place stator (2) over rotor and bring flange up to

grooved face of body. Place stator support ring (13) on stator. Place 'o' ring (11) in position. Place end cover (1) over stator, ensuring that the locating dowel is to the bottom. Insert bolts (7) screw on nuts (8) and tighten in position. Couple up inlet and outlet lines.

NOTE: DO NOT FORGET TO REMOVE FILLING PLUG (3) TO FILL PUMP WITH LIQUID FOR LUBRICATION BEFORE STARTING.

Exploded View

EXPLODED VIEW GRIFTER SCP25 PUMP / SPARE PARTS

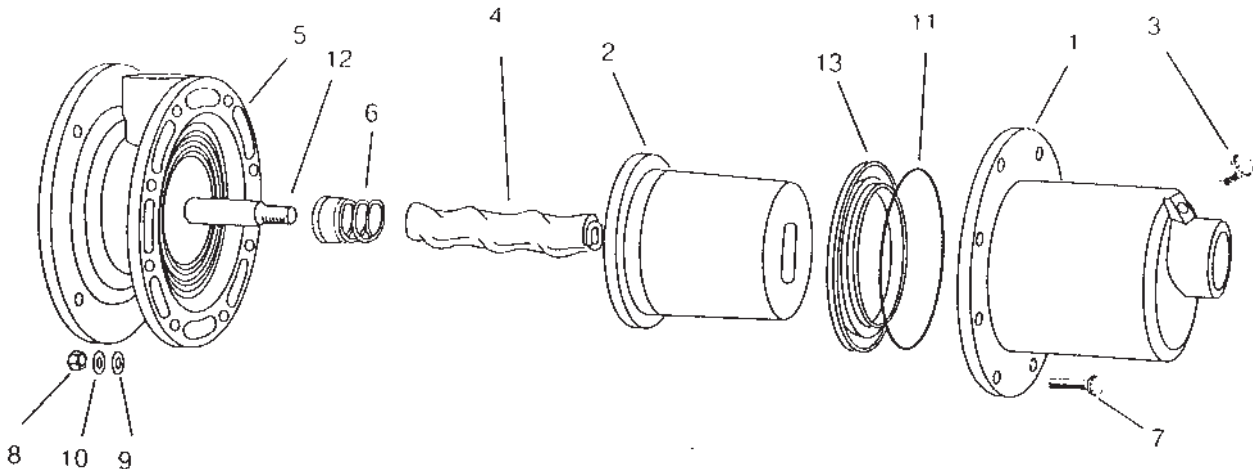

Item No.	Part No.	Description	Qty.
1	CP11 2400 AC	End Cover	1
2	CP25 2200 RR	Stator RR (black nitrile)	1
3	CP00 0430 OO	Plug	1
4	CP25 2500 SF	Rotor SB (stainless steel)	1
5	CP11 0100 AC	Body	1
6	CP11 1050 CE	Mechanical seal (stainless steel)	1
7	K112242F	End Cover Bolt	8
8	N112102F	End Cover Nut	8
9	W112052F	Flat Washer	8
10	W091471F	Lock Washer	8
11	CP11 2010 RA	O Ring	1
*12	CP25 3210 SF	Stub Shaft	1
13	CP25 4700 AC	Stator Support Ring	1

*Only occurs in models with Crompton motor. With CMG motor stub shaft is part of motor shaft.

Exploded View

EXPLODED VIEW OF GRIFTER M12 MACERATOR AND SPARE PARTS

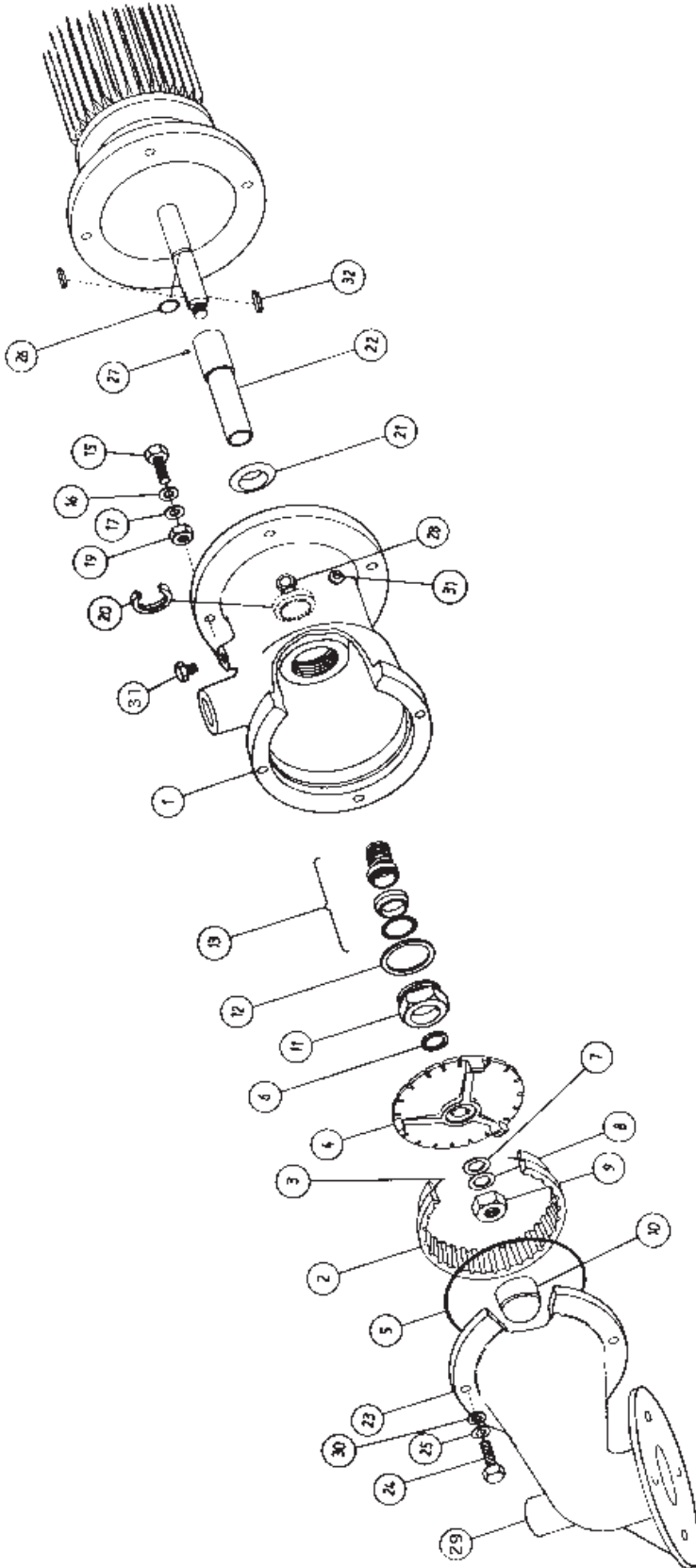

Item	Description	Qty	Part Number
1	125 Mac. Main Casing	1	CD M125 0100
2	Cutter Ring (125 Mac.)	1	TS M125 3000
3	O' Ring (133x137x1.78)	1	S210500P
4	Impeller (125 Mac.)	1	LE M125 3500
5	O' Ring (149.5x3)	1	S111000P
6	Imp/Shaft Seal Washer (Brass)	1	GT M125 4551
7	Imp/Shaft Seal Washer	1	00 M125 4550
8	M12 Plain Washer	1	W115051F
9	M12 Hex "Nylock" Nut	1	40525
10	Plastic Nut Sheath	1	40527
11	Retaining Boss (125)	1	SC M125 4000
12	Sealing Washer	1	ZG M125 4560
13	Mech Seal Assy. 30 Dia	1	40533
14	M10x35LG Hex. HD. S/S Screw	4	F114261F
15	M10 SGL. S/S Coil Spr. Wash	4	W114251F
16	125 Mac. Main Casing	1	CD M125 0201
17	Cutter Ring (125 Mac.)	1	F112161F
18	O' Ring (133x137x1.78)	1	W112251F
19	Impeller (125 Mac.)	1	S210170P
20	O' Ring (149.5x3)	1	G111061F
21	Imp/Shaft Seal Washer (Brass)	1	40537
22	Imp/Shaft Seal Washer	1	P100832S
23	M12 Plain Washer	4	W112050P
24	M12 Hex "Nylock" Nut	2	P100332S
25	Plastic Nut Sheath	2	K150618P
26	Retaining Boss (125)	2	
27	Sealing Washer	2	
28	Mech Seal Assy. 30 Dia	2	
29	M10x35LG Hex. HD. S/S Screw	2	
30	M10 SGL. S/S Coil Spr. Wash	2	
31	125 Mac. Main Casing	1	
32	Cutter Ring (125 Mac.)	1	
33	O' Ring (133x137x1.78)	1	
34	Impeller (125 Mac.)	1	
35	O' Ring (149.5x3)	1	
36	Imp/Shaft Seal Washer (Brass)	1	
37	Imp/Shaft Seal Washer	1	
38	M12 Plain Washer	4	
39	M12 Hex "Nylock" Nut	1	
40	Plastic Nut Sheath	1	
41	Retaining Boss (125)	1	
42	Sealing Washer	1	
43	Mech Seal Assy. 30 Dia	1	
44	M10x35LG Hex. HD. S/S Screw	4	
45	M10 SGL. S/S Coil Spr. Wash	4	

Pump Performance



Europe

Mono Pumps Ltd, Martin Street, Audenshaw
Manchester, M34 5JA, England
T. +44 161 339 9000
E. info-mono@nov.com

D.M.I EST, 56, rue du Pont
88300 Rebeuville, France
T. +33 3 29 94 26 88
E. dmi-est@dmi-est.fr

Americas

Monoflo Inc., 8708 W. Little York, Suite 100
Houston, Texas 77040, USA
T. +1 281 854 0300
E. monoflo@nov.com

Monoflo S.A., Ing Huergo 2239
(1842) Monte Grande
Pcia. de Buenos Aires, Argentina
T. +54 11 4290 9940/50
E. info.monoflo@nov.com.ar

Monoflo Canada, 6010 – 53rd Ave
Alberta, Lloydminster
T9V2T2, Canada
T. + 1 780 875 5584
E: info.monoflo@nov.com

Asia

Mono Pumps Ltd, Building 5,
Madong Industrial Park, 1250 Sicheng Rd
Malu Town, Jiading District, Shanghai 201801
T. +86 21 3990 4588
E. monoshanghai@nov.com

Australasia

Mono Pumps (Australia) Pty Ltd
75 Frankston Gardens Drive
Carrum Downs, Victoria 3201, Australia
T. 1800 333 138
E. ozsales@mono-pumps.com

Mono Pumps (New Zealand) Ltd
35-41 Fremlin Place, Avondale
Auckland, 1026, New Zealand
T. +64 9 829 0333
E. info@mono-pumps.co.nz

Melbourne	T.	03 9773 7777	F.	03 9773 7400
Sydney	T.	02 8536 0900	F.	02 9542 3649
Brisbane	T.	07 3350 4582	F.	07 3350 3750
Adelaide	T.	08 8447 8333	F.	08 8447 8373
Perth	T.	08 9303 0444	F.	08 9303 0400
Darwin	T.	08 8931 3300	F.	08 8931 3200
Kalgoorlie	T.	08 9022 4880	F.	08 9022 3660
Christchurch NZ	T.	+64 3 341 8379	F.	+64 3 341 8486

www.monopumps.com.au



© Mono Pumps Limited April 2011 Literature reference: MPA511

Published information other than that marked CERTIFIED does not extend any warranty or representation, expressed or implied, regarding these products. Any such warranties or other terms and conditions of sales and products shall be in accordance with Mono Pumps Limited standard terms and conditions of sale, available on request.

Mono® is a registered trademark of Mono Pumps Ltd.

Registered in England No 300721

NOV Mono®

One Company, Unlimited Solutions