

Screens and Extraction Packages

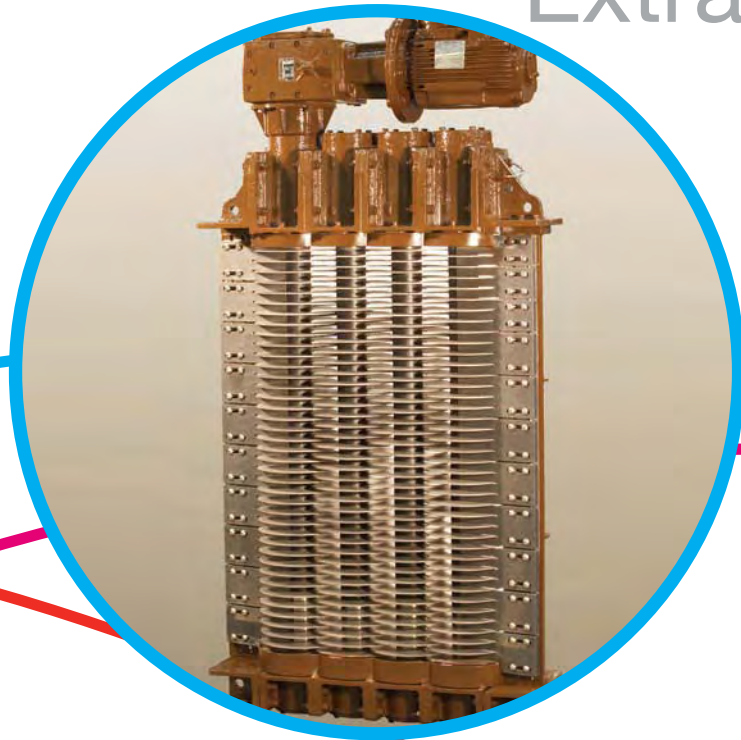

Screening Equipment

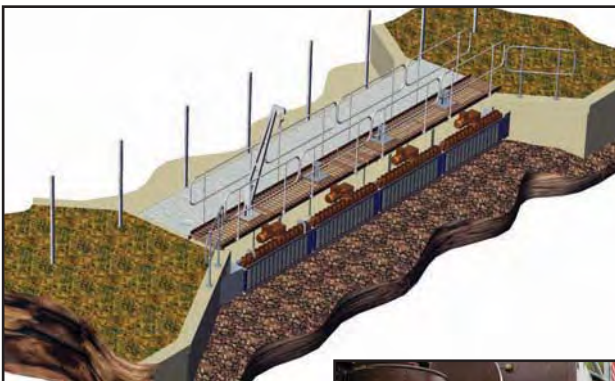

4 Discreens installed at a lagoon intake to screen abstracted water



Water Abstraction Intakes

As river water flows towards the Discreen, solids such as leaves and branches are deflected across the face of the screen, allowing the main intake flow to pass through the disc stacks and into the pump chamber.

Debris is removed from the Discreen by comb bars and remains in the water course, without affecting aquatic wildlife.

With other types of screen, debris is removed by various methods, giving the customer the added expense of disposing of the extracted debris.

The Discreen is self-cleaning and therefore requires no manual attention or need for collection and disposal of debris. Also, there is minimal structure above the river/canal bank level, so the Discreens blend in well with the environment.

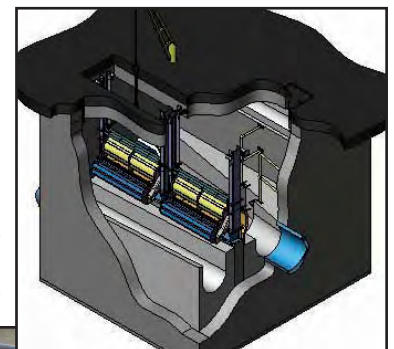

2 Stormscreens installed to screen storm overflows

Storm Overflows

Combat increasingly common flood problems and associated solids discharges with the installation of a Stormscreen.

Simple to retrofit into existing inlet channels or new works designs, the Stormscreen frame is simply bolted onto the storm weir and the unit is lowered into position. During storm conditions, the storm water passes through the 6mm mesh, whilst solids are retained in the main inlet flow for normal treatment or disposal. The self-cleaning Stormscreen also eliminates the need for periodic cleaning.



Applications

Pump Stations

The Discreen can be used in two specific applications found at many city and urban pumping stations:-

1. In conjunction with a Muncher® at invert level to screen and grind the solids to protect the pumps. Also eliminates the risk of reduced pump efficiency and sump septicity.
2. On the overflow pipe to contain the solids within the sump for normal pump disposal.



Discreen / Muncher combination for pump protection



Inlet Works

Leave it In

The Discreen and Muncher package will screen all solids, grind them and retain all the disintegrated faecal matter in the main flow.

Take it Out

A complete extraction package is also available, comprising a Discreen/Muncher combination with screenings removal, compaction and dewatering.

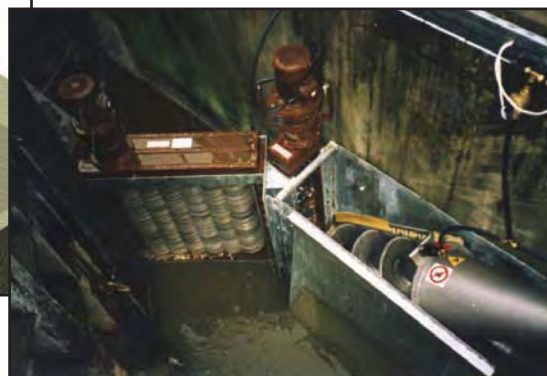
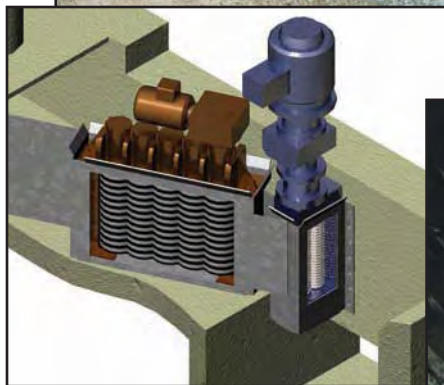

Equipment Installations

Mono Pumps have over the past fifteen years, supplied and installed Mono screening packages within the U.K. to all ten Water Plc's, leading Consulting Engineers and Contractors, Local Councils and Authorities and various industrial end users.

We have also been successful in supplying screening equipment to the following countries:

Australia, Austria, Belgium, Denmark, Finland, France, Germany, Japan, Latvia, Mexico, Poland, Portugal, Russia, Singapore, Slovakia, South Africa, Spain, Turkey, USA.

L Series Discreen® - The Benefits

The Discreen range was first launched in 1991 as 'alternative technology' to the traditional and older mesh, bar and drum screens. The principle design ensures a self cleaning screen that does not block or require manual raking or cleaning.

Operation

The Discreen is constructed using a number of shafts. Each shaft is fitted with discs that overlap and intermesh with corresponding shafts. The shaft rotation forms a gentle conveying action of solids across the face of the screen to the discharge point, whilst allowing water to flow through the disc stacks. Individual comb bars are fitted to the first and last shaft to eject screened solids for discharge back into the main flow or sump area.

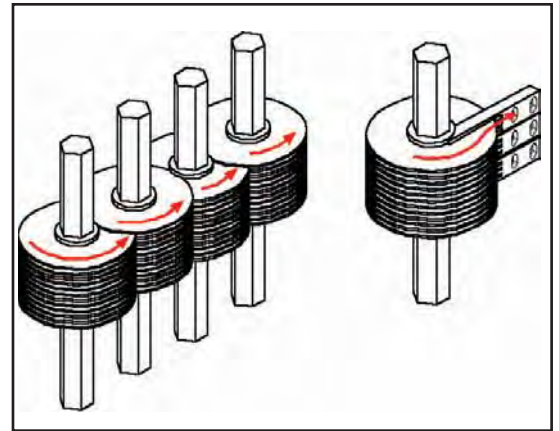

The Discreen principle



Nine Discreens installed in a stormwater pumping station



Design, manufacture and assembly by Mono Pumps

Benefits

- Intermeshing discs give a self cleaning screen area - no frequent raking and no secondary handling system.
- **Head losses are kept to a minimum and are consistent throughout the operation of the unit (unlike bar or mesh screens which can give high head losses between cleaning cycles).**
- Low rotational speed, offers good resistance to abrasion.
- Individual discs allow easy, low cost maintenance should they need replacing. Also allows screening capability to be changed should you require smaller screening of solids.
- **Ability to remove up to 95% of solids with 2.5mm or 5mm aperture sizes.**
- By combining a Discreen with a Mono Muncher, you have the option of keeping all macerated and screened residue in the main flow, eliminating removal costs.
- **The combination of a Discreen, Muncher and screw extractor package provides you with a complete screening extraction and washing system.**

Features and Dimensions

200 - 500 Throats
Capacity up to 2,050m³/h

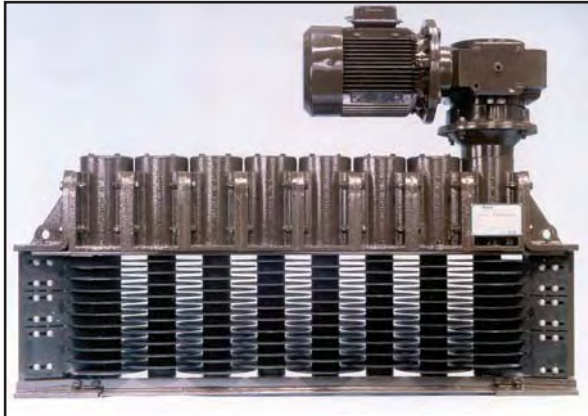

750 - 1750 Throats
Capacity 850m³/h - 26,600m³/h

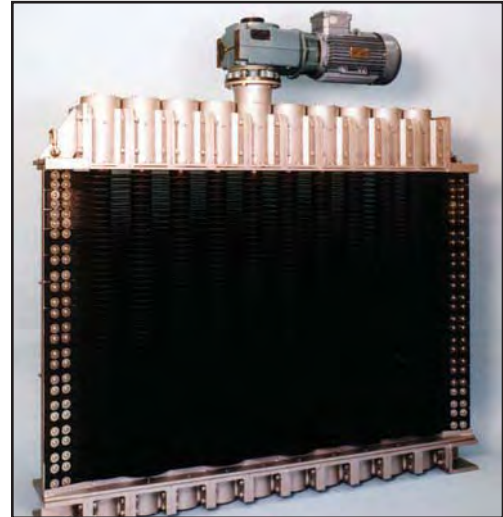

- Various apertures/sizes available, standards being 2.5, 5.0, and 9.0mm. 13.0 and 18.0mm options also available.
- Up to 10 shafts per unit, as standard, multiple shafts on request.
- Throat depths available in 200, 300, 400, 500, 750, 1000, 1250, 1500 and 1750mm.
- Modular Construction - stainless steel or polymer discs available.
- Discs manufactured from high impact, glass reinforced polypropylene Verton - resistant to impact damage.
- Drives available as standard TEFC, floodproof, ATEX, extended shaft or hydraulic.
- Full control equipment, including level control and telemetry contacts.

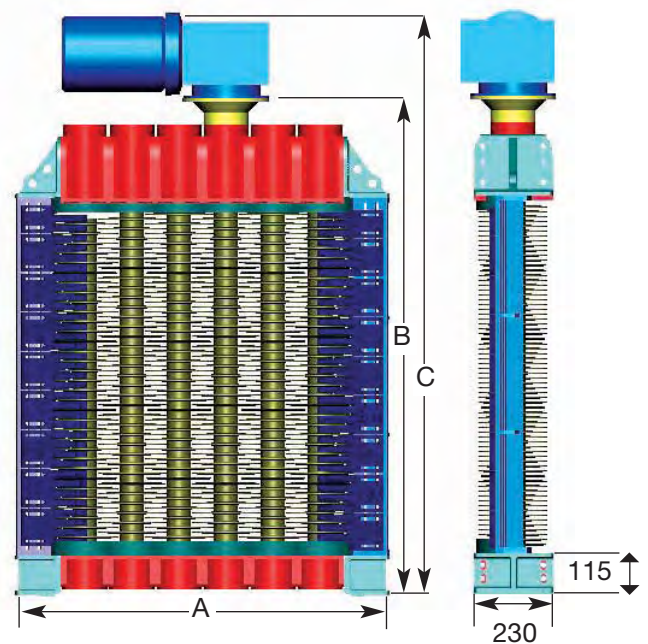

Dimensions Standard Range

NOMINAL THROAT SIZE (mm)	DIMENSION A (mm)									Dimension B (mm)	Dimension C (mm)	Maximum Weight (kg) 3 shaft	Add per Additional Shaft (kg)	Maximum* Capacity m ³ /h
	3	4	5	6	7	8	9	10						
200	676	812	948	1084	1220	1356	1492	1628	565	775	225	26	518	
300									665	875	245	34	952	
400									765	975	260	41	1466	
500									865	1075	280	50	2049	
750									1185	1460	505	115	3765	
1000									1435	1710	590	137	5797	
1250									1685	1960	655	160	8102	
1500									1935	2210	755	181	10651	
1750									2185	2460	835	203	13422	

Notes

* Based on a standard 10 shaft unit, for higher capacities consult Mono.

1. These dimensions are for guidance only.
2. For full certified drawings relating to installation details, please refer to Mono.

Stormscreen

The Stormscreen was designed by Mono as an economic solution for storm overflows at inlet and CSO installations. This new, flow powered, self cleaning screen has no electrical or running costs and therefore offers low maintenance combined with efficient and effective screening.

Operation

A standard 400mm or 700mm diameter mesh drum incorporates a brush wheel, fitted with adjustable brushes. As waste water flows into the channel and through the unit, solids above 6mm are captured on the mesh. The screened flow powers a paddle wheel which is mounted below the mesh drum. This drives the brush wheel via a belt and pulleys and the brushes clean the mesh drum, returning any solids back into the main flow.



Operational Benefits

- Self Cleaning.
- Simple design - low maintenance requirements.
- Efficient screening - conforms to discharge consent requirements.
- Low operating head - capable of handling small flows that suit standard long weir installations.
- Modular construction - adaptable to existing civil works.
- Optional diameters and lengths to suit differing weir lengths.
- Integrated scum board.
- Optional monitoring system offers status report and event logging.

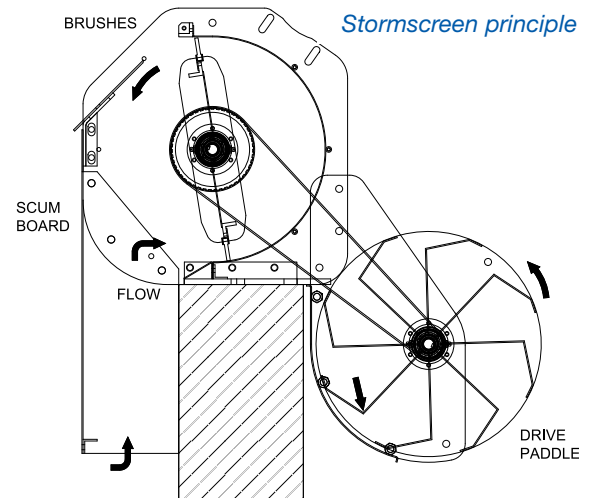

Rotating Brush Arms



6mm Smooth Profile Mesh

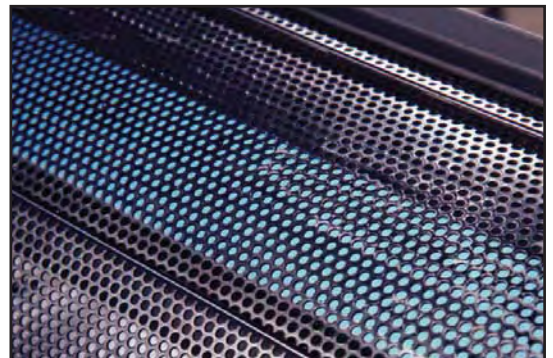

Features and Dimensions



*The Mono Stormscreen
an economical solution to storm
overflow applications*

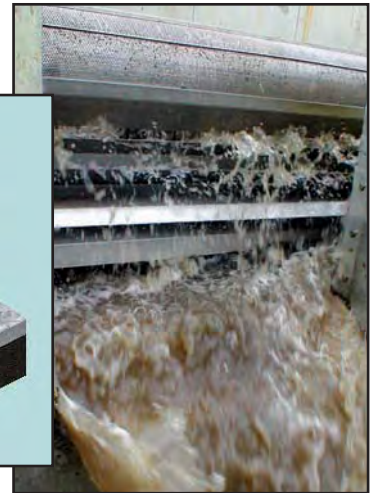
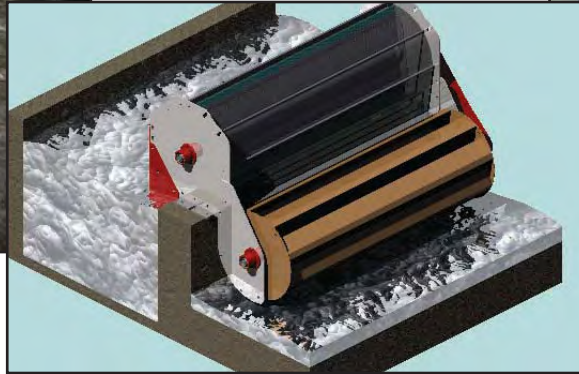

Flow Rates

Drum Size (mm)	Machine Width (m)	Maximum Flow Capacity (l/s)
400	0.75	118
	1.00	172
	1.25	214
	1.50	258
	1.75	300
	2.00	345
700	0.75	305
	1.00	406
	1.25	507
	1.50	608
	1.75	710
	2.00	810

Note: Above figures are calculated assuming a 6mm mesh aperture size and maximum head loss = drum diameter.

Dimensions

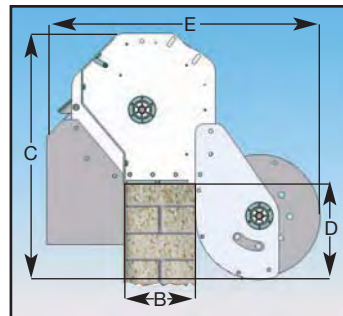
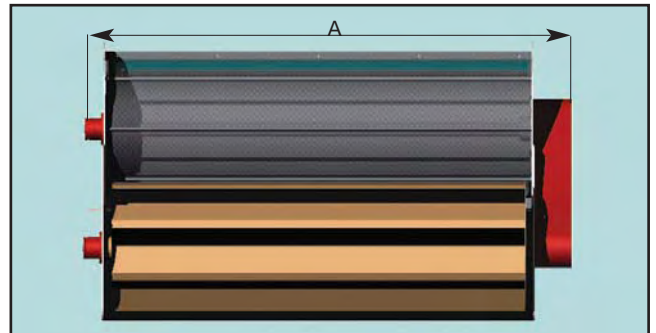

Maximum weight:

400mm = 265kg
700mm = 400kg

Materials of Construction

Mesh	6mm 304 stainless steel profile as standard (316 available)
Brushes	Nylon 612 - adjustable
Body	304 stainless steel (316 available)
Bearings	Sealed for Life
Scum Board	Incorporated - 304 stainless steel

- 6mm diameter screening aperture as standard, other mesh sizes available.
- Minimum head loss.
- Electrical motor drive option available.
- Capable of passing through existing manholes.

Drum Diameter	Width	Dimension (mm)				
		A	B	C	D	E
400mm	0.75m	920	234	807	316	896
	1.00m	1170				
	1.25m	1420				
	1.50m	1670				
	1.75m	1920				
	2.00m	2170				
700mm	0.75m	920	330	1240	475	1235
	1.00m	1170				
	1.25m	1420				
	1.50m	1670				
	1.75m	1920				
	2.00m	2170				

Note: (Standard with 300mm scum board)
These dimensions are for guidance only,
please contact Mono for certified drawings.

Screening Extraction Systems

Inlet Works Applications

When full extraction and washing of organic solids from inflows to sewage treatment works is needed, Mono can supply a number of solutions.

Our complete extraction package comprises three combinations of Discreen®, Muncher® and screw extractor for screenings removal.

Operation

Once solids have been screened and disintegrated by the Discreen and Muncher, the material collects on the perforated screen surface as the incoming water flows through it. A level switch operates the rotating screen spiral to run for the time necessary to clean the screen and convey the solids towards the discharge chute for removal.



Inlet Works installation at a WWTW in Eire

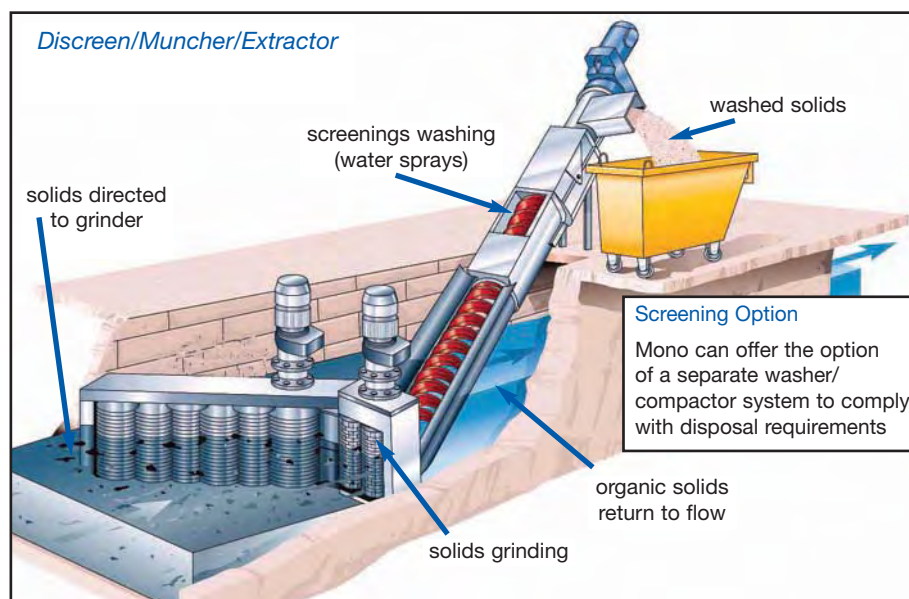

Operational Benefits

- Equipment and installation flexibility allows many different channel widths and depths to be covered.
- Dynamic, self cleaning Discreen, with high capture rate efficiency, eliminates the problem of ragging and material build up. Modular design, 3-10 shafts per unit.
- The Muncher operates at a low speed with lower wear rates and power requirements than other designs of grinder.
- Screw extractor washes and dewateres screenings, so minimising the extent of secondary equipment.
- Consistent head losses create stable upstream and downstream depths.

Performance Features



Discreen/Extractor Inlet Package



- Swivel support and an easily replaceable part of the spiral along the screen, simplify service and cut maintenance costs.
- Bolted covers for easy access to all parts.
- Enhanced extractor performance when used in conjunction with a Muncher.
- Minimum or no civil works required when fitting into existing channels.
- Screw extractor discharge port can be rotated to any required position so simplifying installation and saving space.
- Optional bagging and dewatering / compaction units available.
- Drives available as standard TEFC, floodproof, ATEX, extended shaft or hydraulic.

Capacities

Channel Depth	Extractor CS300 / CS500 l/sec	Muncher/ Extractor l/sec	Discreen Extractor l/sec
0.50	69 / 125	28	597
0.75	69 / 125	40	1104
1.00	69 / 125	95	1708
1.25	69 / 125	110	2375
1.50	69 / 125	180	3084
1.75	69 / 125	220	3853

Note: Capacities based on typical head loss of 300mm.

Specification	Model	
Width screen section, mm	300	500
Length screen section)	
Length transport section) to suit installation	
Height cross discharge)	
Screen deck perforation	3mm or 5mm	3mm or 5mm
Drive unit kW	1.1	1.5
Max screen capacity l/s at screen length mm	69 900	125 1500
Material	Stainless steel AISI 304, except spiral and drive unit	

Dimensions and Control Equipment

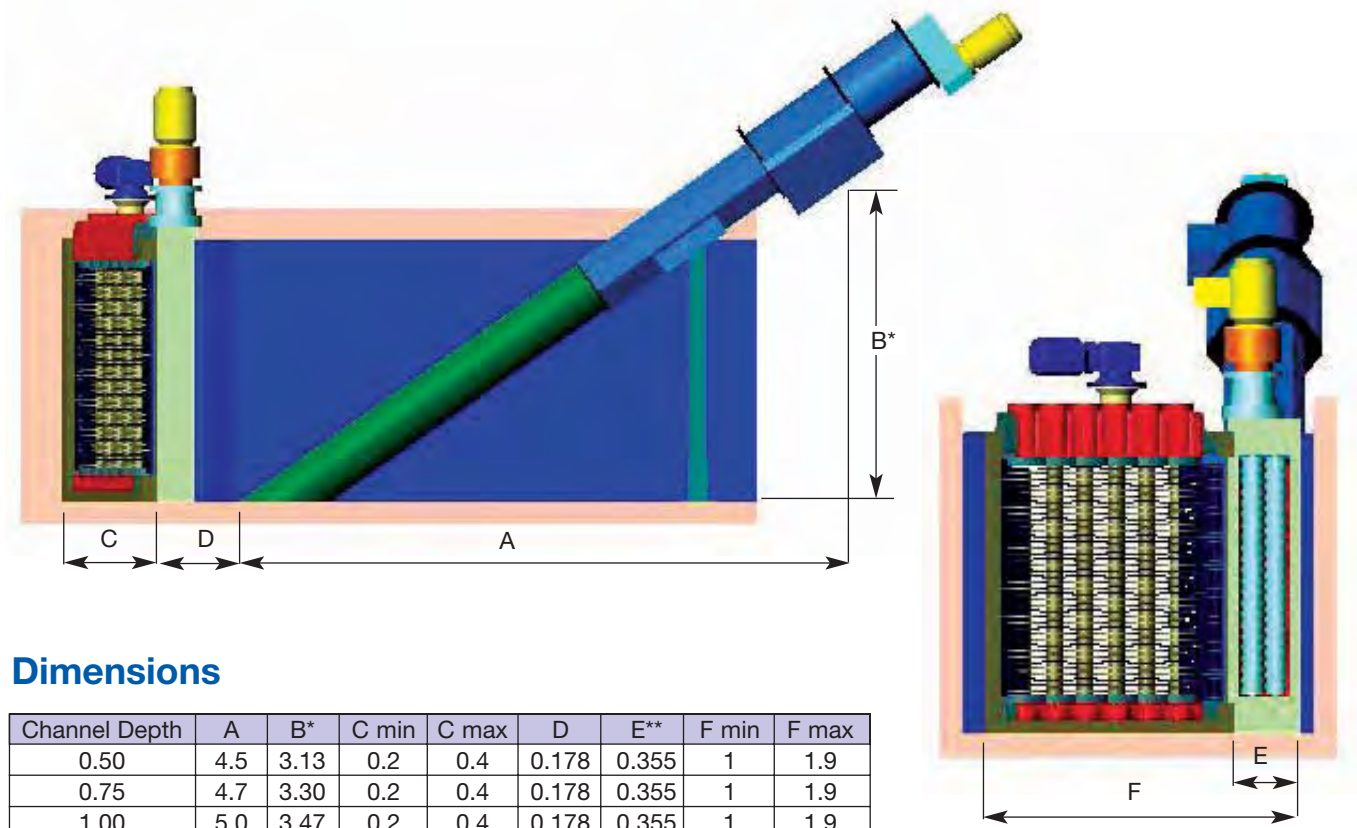

Dimensions

Channel Depth	A	B*	C min	C max	D	E**	F min	F max
0.50	4.5	3.13	0.2	0.4	0.178	0.355	1	1.9
0.75	4.7	3.30	0.2	0.4	0.178	0.355	1	1.9
1.00	5.0	3.47	0.2	0.4	0.178	0.355	1	1.9
1.25	5.4	3.81	0.2	0.4	0.178	0.355	1	1.9
1.50	5.7	3.99	0.2	0.4	0.178	0.355	1	1.9
1.75	6.2	4.33	0.2	0.4	0.178	0.355	1	1.9

Dimensions in metres
and for guidance only

Note: Alternative arrangements are available to suit different channel widths

* Assumes skip height 1.2m above coping; A & B relate to discharge point

** Dimension E is minimum channel width for a Muncher or extractor only

Control Equipment

Mono Pumps supply control equipment for all their screen and equipment packages compliant to all U.K. Water Company standards, Sewers for Adoption and most international standards including I.E.C., N.E.M.A., and Australian.

The single compartment is IP55 for use in a safe area and is capable of operating with a 400V / 3ph / 50Hz supply.

Each Muncher and Extractor is supplied with a Programmable Logic Controller (PLC) designed to protect the machine against damage from rogue materials and overloads.

This logic control unit is programmed to operate in the following manner:

1. To operate in a normal On/Off mode.
2. To sense an overload condition (jam), momentarily reverse the unit to clear the condition and then return to normal operation.
3. If a third overload (jam) occurs within 60 seconds of the first, the machine will then automatically shut down in reversed mode and an alarm circuit will be energised. (Alarm not supplied in standard packages).

Full Turnkey Installations

Whilst renowned for manufacturing progressing cavity pumps, grinders and screens, Mono also offer a complete range of other services designed to compliment our product ranges and give you a total engineered system solution. Whatever your industry, at Mono we are able to offer a complete package from initial concept through to maintenance and service, including:-

- Design.
- Supply.
- Mechanical & Electrical Installation.
- Commissioning.
- Service Contract.



To complete a project on a turnkey basis, Mono also offer other associated equipment. Such items would include:

- Control Panels.
- Walkways.
- Lifting Equipment.
- Minor Civil Work. (plinths, ducting, etc.)
- Instrumentation flow meters, pressure transducers, PLC controllers etc.
- Kiosks.
- Fencing.
- Conveyors.
- Domestic Electrics etc.
- Industrial Electrics.
- Pipework & Valves.

Contract Status

We can act as main contractor with full control of the project. Our site supervision teams have all undertaken the IOSH Managing Safely course and are fully conversant with the CDM regulations. As an example, Mono was the main contractor for a project based in the North West. This involved the installation of 4 Discreens underwater on the inlet to a clean water pumping station, requiring a period of 10 weeks on site. Based on the success of this contract, we have now carried out a number of similar installations. Subject to approval, we can handle M&E projects up to £500,000.00.

Accredited to ISO 9001:2000, Mono Pumps Ltd are approved by all U.K. water PLC's and major civil contractors.

Financially secure, Mono is part of National Oilwell Varco, a global supplier of process solutions. This enables us to continually focus on product research and development for new materials, new designs, new processes and new technology, all to support you the customer.

Installations

Installations are handled by a dedicated project team ensuring all aspects of contract management are effectively covered.

All installation work is carried out by fully trained and approved engineers including:

- Confined Space.
- Hazardous Area.
- Qualified Underwater Diving Team.
- NICEIC Approved and Certified.
- IOSH/CITB Safety Approved.

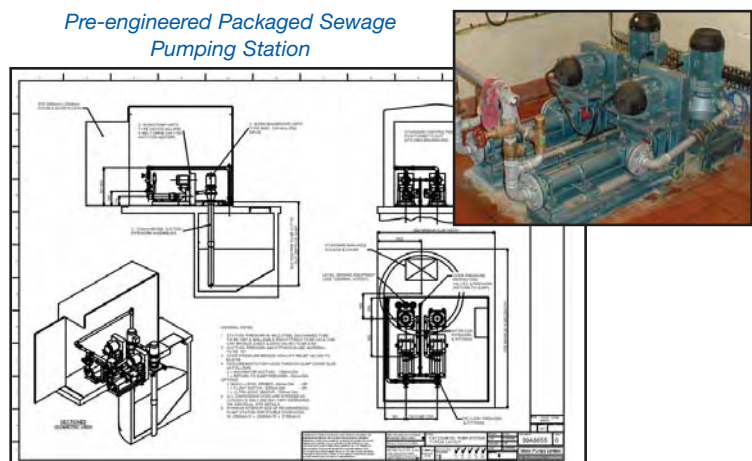

Europe

Mono Pumps Ltd, Martin Street, Audenshaw
Manchester, M34 5JA, England
T. +44 (0)161 339 9000
E. info@mono-pumps.com

D.M.I EST, 56, rue du Pont
88300 Rebeuville, France
T. +33 (0)3 29 94 26 88
E. dmi-est@dmi-est.fr

Americas

NOV Monoflo Inc., 9606 Kirkton Drive
Houston, Texas 77095, USA
T. +1 281 200 1200
E. inquire@monoflo.com

NOV Monoflo S.A., Ing Huergo 2239
(1842) Monte Grande
Pcia. de Buenos Aires, Argentina
T. +54 11 4290 9940/50
E. info@monoflo.com.ar

NOV Monoflo, 5702 63rd Ave
Alberta, Lloydminster
T9V0Y4, Canada
T. +1 780 875 5504
E. info.monoflo@nov.com

Australasia

Mono Pumps (Australia) Pty Ltd
Mono House, 338-348 Lower Dandenong Road
Mordialloc, Victoria 3195, Australia
T. 1800 333 138
E. ozsales@mono-pumps.com

Mono Pumps (New Zealand) Ltd
PO Box 71-021, Fremlin Place, Avondale
Auckland 7, New Zealand
T. +64 (0)9 829 0333
E. info@mono-pumps.co.nz

Asia

Mono Pumps Limited, Building 5, Madong Industrial Park
1250 Sicheng Road, Malu Town, Jiading District
Shanghai 201801, P.R. China
T. +86 (0)21 3990 4588
E. monoshanghai@nov.com

www.mono-pumps.com



Published information other than that marked CERTIFIED does not extend any warranty or representation, expressed or implied, regarding these products. Any such warranties or other terms and conditions of sales and products shall be in accordance with Mono Pumps Limited standard terms and conditions of sale, available on request.

© Mono Pumps Limited May 2010 Literature reference: SLMP/042/01/R8

Mono®, Discreen® and Muncher® are registered trademarks of Mono Pumps Ltd.
Registered in England No 300721



One Company, Unlimited Solutions