

# EZstrip™ TR Muncher®

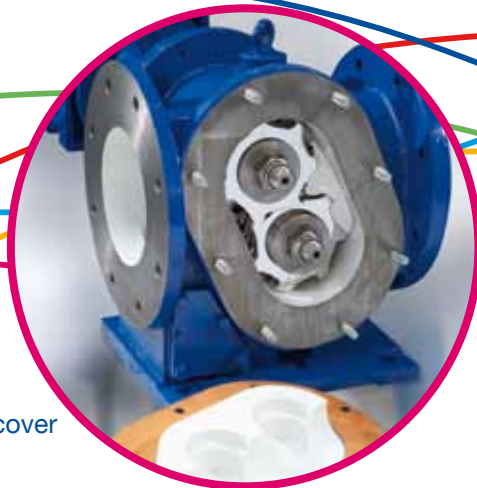

**NOV** Mono®

One Company, Unlimited Solutions



Large access cover

## What can you do in 2½ hours?

Mono first began manufacturing progressing cavity pumps in 1935, followed by the Mono Muncher® range of grinders in 1981 and has continued to engineer industry leading products for over 75 years.

The new EZstrip™ pump design was launched in 2009 offering a range of operation and maintenance benefits and has proved to be a great success amongst end users.

Following on from this successful launch we have now incorporated the same maintenance benefits into our Muncher® range of grinders offering an option for a complete EZstrip™ package.

## EZstrip™ TR Muncher®



## Features & Benefits

The EZstrip™ TR Muncher® is an extension to our Muncher® range of grinders, offering a choice of cutter materials and thickness for effective and efficient grinding of solids.

- Full access port allowing ease of inspection (CT201).
- Maintain in place of the cutters and spacers (CT201).
- Easily removed cutter stack.
- No special tools required.
- Reduced maintenance downtime.
- Increased labour savings.
- No need to disconnect pipework.
- Operational parameters are unaffected.

---

Capacity	up to 440m <sup>3</sup> /hr on raw sewage
----------	---

---

	up to 330m <sup>3</sup> /hr on 4% sludge
--	--



## Maintain in Place (M.I.P.)

To minimize the time and cost involved when maintaining a conventional grinder/macerator, the EZstrip™ can easily be maintained in place, without disconnecting or removing any pipework.

Currently, the removal of the cutting elements from a typical grinder/macerator requires removal from site and can take up to two days to complete.

With the EZstrip™, the complete cutter stack can be inspected and replaced within two and a half hours.

1. CT201 - Clear access to cover screw



2. Remove retaining screws



3. Remove large access cover for visual inspection of cutters



4. Loosen and remove shaft lock nuts



5. Remove cutters and spacers



6. Inspect/replace cutters, spacers and shafts



## Performance Data

MODEL	% D.S/ M <sup>3</sup> /HR				
	0	2	4	6	8
CT201	118	100	85	63	52
CT203	242	210	183	155	125
CT205	440	388	330	276	225



Rotating parts are easy to replace

## Cost Savings

To fully appreciate the potential cost savings when installing an EZstrip™ Muncher®, the following examples have been calculated:

### CUTTER INSPECTION

	Standard	EZstrip™
Maintenance time Inspection	90 minutes	30 minutes
Labour cost per inspection	\$147.00	\$49.00
<b>SAVINGS PER INSPECTION</b>		<b>\$98.00</b>

### CUTTER REPLACEMENT

	Standard	EZstrip™
Time to replace cutters/spacers	9 hours	2 1/2 hours
Cost per replacement	\$882.00	\$245.00
<b>TOTAL SAVINGS</b>		<b>\$637.00</b>

Inspection and maintenance hours per muncher life	60	17.5
Cost over muncher life	\$5880	\$1,715
<b>SAVINGS OVER MUNCHER LIFE</b>		<b>\$4,165</b>

Maintenance hours per muncher life for full asset base	900	263
Cost over muncher life	\$88,200	\$25,774
<b>SAVINGS OVER MUNCHER LIFE - FULL ASSET BASE</b>		<b>\$62,426</b>

### ASSUMPTIONS

Labour costs per hour	\$98.00
Muncher life	10 years
Asset base / Muncher population	15

A typical Grinder will have one annual inspection and one maintenance intervention every two years.

Calculations based on a standard size CT201 TR Muncher®

### Maintain in place

Quick and easy removal of rotating parts with no electrical disconnection required.

### Cartridge assembly

A pre-assembled cutter cartridge is available, with a 2 year warranty, to allow an even faster re-assembly time.

### Service Exchange

A complete, competitively priced, replacement unit can be provided on a short lead time to reduce strip and repair down time and costs.

### Energy efficiency motors

As an additional benefit to the low installation power we now fit motors to reduce operating costs further.

### Low running speeds

Reduced wear for a longer working life which extends the periods between routine maintenance.

# Dimensions (mm)

## CT201

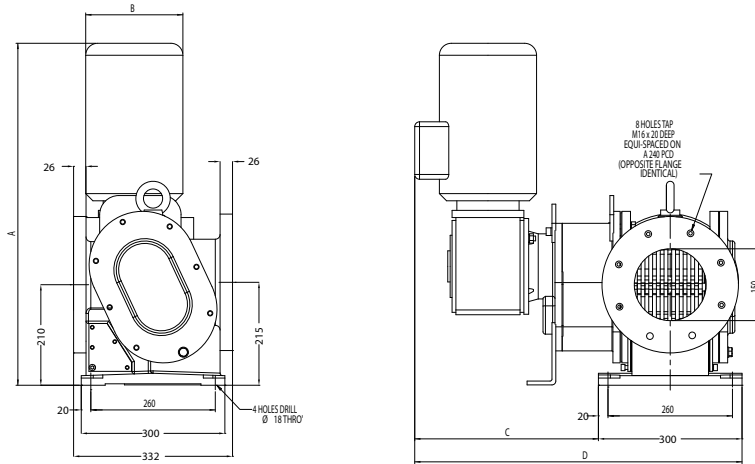

Model No	kW	A	B	C	D	Wt Kg (Approx)
CT201D	1.5	700	186	382	682	140
CT201D	2.2	715	203	382	682	175

## CT203/205

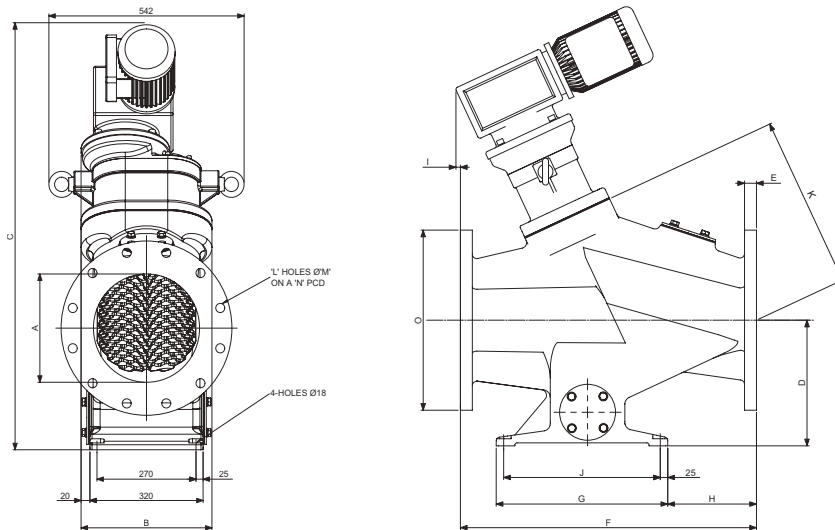

MODEL No.	kW	A	B	C	D	E	F	G	H	I	J	K	L	M	N	O	Wt. Kg
CT203C	1.5	100	370	1020	205	24	489	410	124	140	360	363	8	18	180	220	290
CT203D		150	370	1050	230	25	540	410	155	40	360	354	8	22	240	285	290
CT203E		200	370	1050	256	29	591	410	205	16	360	341	12	22	295	343	290
CT205F		250	370	1190	281	32	692	460	205	30	410	494	12	26	355	406	345
CT205G		300	370	1190	332	32	794	460	263	-17	410	472	12	26	410	483	345
CT203C	2.2 - 4.0	100	395	1130	205	24	489	410	124	169	360	363	8	18	180	220	340
CT203D		150	395	1170	230	25	540	410	155	97	360	354	8	22	240	285	340
CT203E		200	395	1170	256	29	591	410	205	72	360	341	12	22	295	343	340
CT205F		250	395	1310	281	32	692	460	205	87	410	494	12	26	355	406	390
CT205G		300	395	1310	332	32	794	460	263	40	410	472	12	26	410	483	390

## Europe

Mono Pumps Ltd, Martin Street, Audenshaw  
Manchester, M34 5JA, England  
T. +44 161 339 9000  
E. [info-mono@nov.com](mailto:info-mono@nov.com)

D.M.I EST, 56, rue du Pont  
88300 Rebeuville, France  
T. +33 3 29 94 26 88  
E. [dmi-est@dmi-est.fr](mailto:dmi-est@dmi-est.fr)

## Americas

Monoflo Inc., 8708 W Little York Rd  
Houston, Texas 77040, USA  
T. +1 281 200 1200  
E. [monoflo@nov.com](mailto:monoflo@nov.com)

Monoflo S.A., Ing Huergo 2239  
(1842) Monte Grande  
Pcia. de Buenos Aires, Argentina  
T. +54 11 4290 9940/50  
E. [info.monoflo@nov.com.ar](mailto:info.monoflo@nov.com.ar)

Monoflo Canada, 6010 – 53rd Ave  
Alberta, Lloydminster  
T9V2T2, Canada  
T: + 1 780 875 5584  
E: [info.monoflo@nov.com](mailto:info.monoflo@nov.com)

## Asia

Mono Pumps Ltd, Building 5,  
Madong Industrial Park, 1250 Sicheng Rd  
Malu Town, Jiading District, Shanghai 201801  
T. +86 21 3990 4588  
E. [monoshanghai@nov.com](mailto:monoshanghai@nov.com)

## Australasia

Mono Pumps (Australia) Pty Ltd  
75 Frankston Gardens Drive  
Carrum Downs, Victoria 3201, Australia  
T. 1800 333 138  
E. [ozsales@nov.com](mailto:ozsales@nov.com)

Mono Pumps (New Zealand) Ltd  
35-41 Fremlin Place, Avondale  
Auckland, 1026, New Zealand  
T. +64 9 829 0333  
E. [info@mono-pumps.co.nz](mailto:info@mono-pumps.co.nz)

Melbourne	T.	03 9773 7777	F.	03 9773 7400
Sydney	T.	02 8536 0900	F.	02 9542 3649
Brisbane	T.	07 3350 4582	F.	07 3350 3750
Adelaide	T.	08 8447 8333	F.	08 8447 8373
Perth	T.	08 9303 0444	F.	08 9303 0400
Darwin	T.	08 8931 3300	F.	08 8931 3200
Kalgoorlie	T.	08 9022 4880	F.	08 9022 3660

[www.monopumps.com.au](http://www.monopumps.com.au)



© Mono Pumps Limited June 2011 Literature reference: ART81

Published information other than that marked CERTIFIED does not extend any warranty or representation, expressed or implied, regarding these products. Any such warranties or other terms and conditions of sales and products shall be in accordance with Mono Pumps Limited standard terms and conditions of sale, available on request.

Mono® is a registered trademark of Mono Pumps Ltd.

Registered in England No 300721



One Company, Unlimited Solutions