

CP Brochure

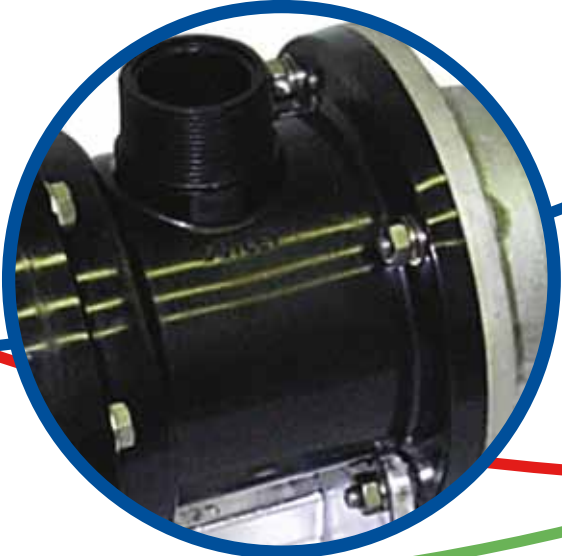

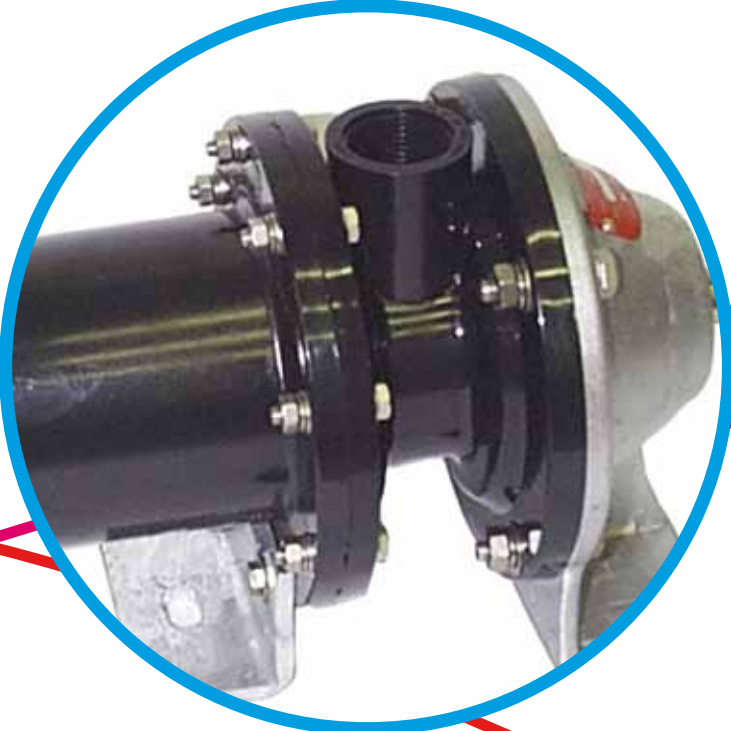
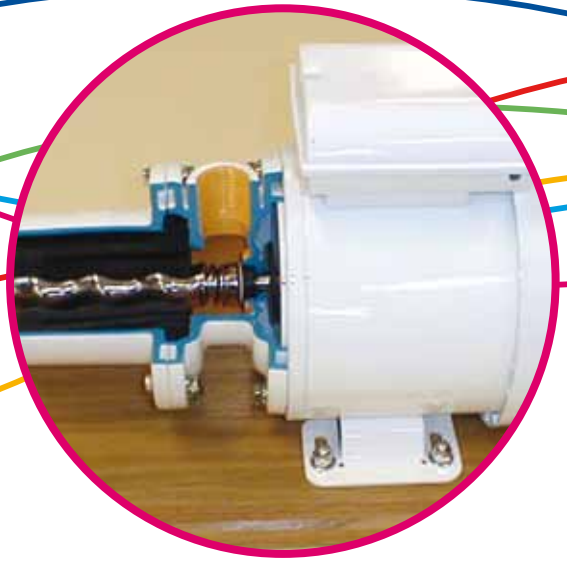

The Great Little All-Rounder:

NOV MONO® CP RANGE PUMPS:

Simple design. Sturdy lightweight construction. Conveniently compact.

Whether for domestic pumping requirements, or light industrial duties - they'll keep up with the pressure of work!

Four models available (CP11, CP25, CP800 and CP1600) each operating on the well proven "progressive cavity" principle, and between them a variety of performance capabilities, up to a maximum capacity of 1650 gph (125lpm), and pressures of up to 92 feet (28 metres).

STATOR OPTIONS:

- Natural.
- Nitrile (Standard).
- Hypalon.
- High Nitrile.
- Fluoroelastomer (CP11 and CP25 only).

THE NOV MONO® PRINCIPLE:

The CP uses the famous helical rotor pumping principle.

The heart of the Mono Pump is the single helix metal rotor which rotates eccentrically within a double helix resilient stator of twice the pitch length of the rotor. The rotor of circular cross section creates a continuously forming cavity as it rotates. The cavity progresses towards the discharge end, advancing in front of a continuously forming seal line, carrying the pumped material with it. As the stator open cross sectional area is always constant the flow rate is continuous without pulsation.

THE PRINCIPLE BENEFITS ARE:

1. Capacity is proportional to speed.
2. Self priming even with entrained air.
3. Can handle a variety viscous materials.
4. Minimal damage to shear sensitive products.
5. Can handle liquids containing solids or abrasive particles.
6. Pulsation free operation.
7. Positive displacement.

Bareshaft & Motorised:

CP11 & CP25 Bareshaft

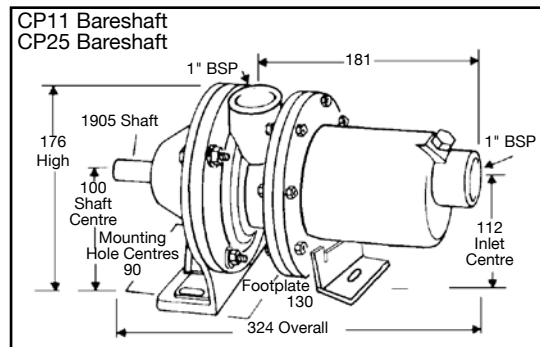

CP800 & CP1600 Bareshaft

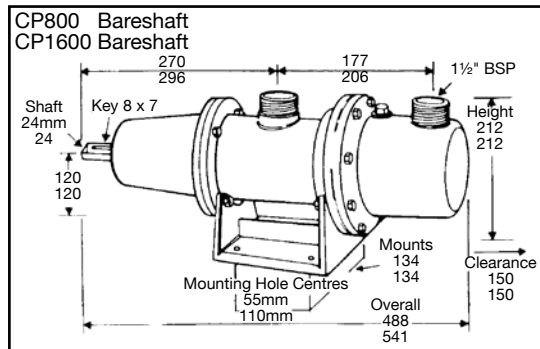

CP11 & CP25 Motorised

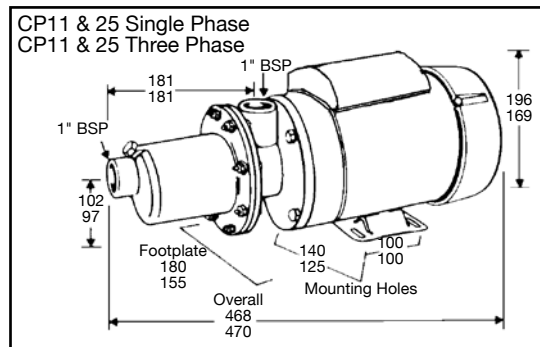

CP800 & CP1600 Motorised

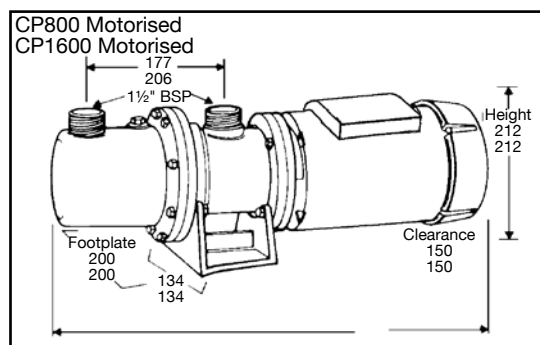



Pre-selection Information

FEATURES & BENEFITS:

Single mechanical seal	Low maintenance
Self priming up to 6 m	High suction lifts
Tough engineered grade acetal co-polymer plastic housing	Long lasting, low replacement costs
Stainless steel internal rotating parts	Corrosion free, long life
Close coupled drive arrangement	Compact in size
Simple and easy to maintain	Low maintenance
Integral mounting bracket	Ease of installation
Tropical proof motor as standard	Can be installed outside
BSP threaded port connections	Ease of installation
Stainless Steel fasteners	Long Life
Bareshaft options	Optional drive selections

PERFORMANCE TABLE:

Flows to:	CP11	11 lpm
	CP25	25 lpm
	CP800	60 lpm
	CP1600	125 lpm
Heads to:	28 metres	
Motor options:	240v and 415v	
Maximum speed:	1450 rpm	
Lead length:	2 metres (240v only)	

SUCTION CURVES:

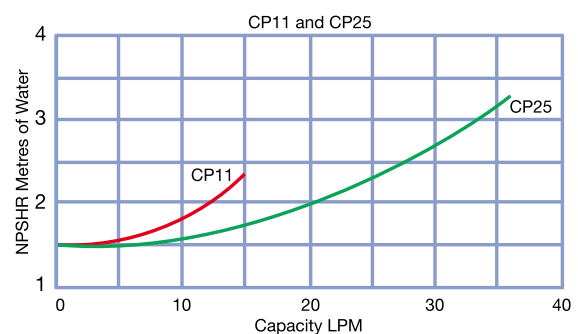
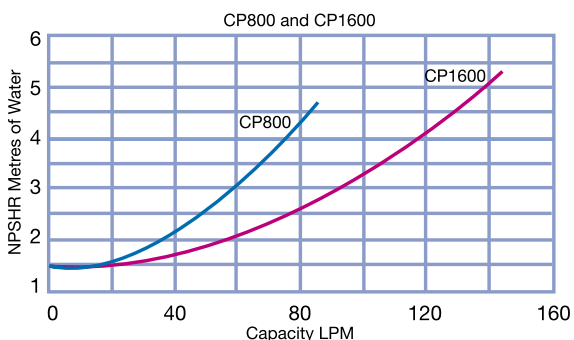

* For pressures above 28 metres contact Mono Pumps Technical Support on 1800 333 138.

Typical products/applications:

- Milk
- Honey
- Food colour
- Fruit juice
- Wine
- Detergents
- Mustard
- Domestic Water Supply
- Septic Effluent
- Brine injection for meat curing
- Oily water
- Molasses transfer stock feed



MOLASSES FEED PUMP UNIT



SHALLOW BORES



TROLLEY UNIT WINE TRANSFER



OILY WATER SEPARATOR

Europe

Mono Pumps Ltd, Martin Street, Audenshaw
Manchester, M34 5JA, England
T. +44 161 339 9000
E. info-mono@nov.com

D.M.I EST, 56, rue du Pont
88300 Rebeuville, France
T. +33 3 29 94 26 88
E. dmi-est@dmi-est.fr

Americas

Monoflo Inc., 10529 Fisher Road
Houston, Texas 77041, USA
T. +1 713 980 8400
E. monoflo@nov.com

Monoflo S.A., Ing Huergo 2239
(1842) Monte Grande
Pcia. de Buenos Aires, Argentina
T. +54 11 4290 9940/50
E. info.monoflo@nov.com.ar

Monoflo Canada, 6010 – 53rd Ave
Alberta, Lloydminster
T9V2T2, Canada
T. + 1 780 875 5584
E: info.monoflo@nov.com

Asia

Mono Pumps Ltd, Building 5,
Madong Industrial Park, 1250 Sicheng Rd
Malu Town, Jiading District, Shanghai 201801
T. +86 21 3990 4588
E. monoshanghai@nov.com

Australasia

Mono Pumps (Australia) Pty Ltd
75 Frankston Gardens Drive
Carrum Downs, Victoria 3201, Australia
T. 1800 333 138
E. ozsales@nov.com

Mono Pumps (New Zealand) Ltd
35-41 Fremlin Place, Avondale
Auckland, 1026, New Zealand
T. +64 9 829 0333
E. info@mono-pumps.co.nz

Melbourne	T.	03 9773 7777	F.	03 9773 7400
Sydney	T.	02 8536 0900	F.	02 9542 3649
Brisbane	T.	07 3350 4582	F.	07 3350 3750
Adelaide	T.	08 8447 8333	F.	08 8447 8373
Perth	T.	08 9303 0444	F.	08 9303 0400
Darwin	T.	08 8931 3300	F.	08 8931 3200
Kalgoorlie	T.	08 9022 4880	F.	08 9022 3660

www.monopumps.com.au



© Mono Pumps Limited May 2011 Literature reference: ART01-7
Published information other than that marked CERTIFIED does not extend any warranty or representation, expressed or implied, regarding these products. Any such warranties or other terms and conditions of sales and products shall be in accordance with Mono Pumps Limited standard terms and conditions of sale, available on request.
Mono® is a registered trademark of Mono Pumps Ltd.
Registered in England No 300721



One Company, Unlimited Solutions